



UNIVERSITY OF ENERGY AND NATURAL RESOURCES, SUNYANI
OFFICE OF THE PROCUREMENT DIRECTORATE

P. O. Box 214, Sunyani

www.uenr.edu.gh

+233 (0) 352 290 367

procurementdirector@uenr.edu.gh

Our Ref: 0000211

MEMO

TO : VICE-CHANCELLOR
FROM : AG. DIRECTOR OF PROCUREMENT
THRU : DIRECTOR, RCEES
DATE : 5TH DECEMBER, 2022
SUBJECT : PAYMENT TO MAT-BANS COMPANY LIMITED

I write to request for Mobilization fee of One Hundred and Twenty-Two Thousand, Eight Hundred and Twenty Ghana Cedis (GH¢122,820.00) to MAT-BANS COMPANY LIMITED representing 15% of the total Contract Sum (GH¢818,800.00) for the supply of Lecture Hall Furniture to Regional Centre for Energy and Environmental Sustainability (RCEES)-UENR

Attached are the relevant documents

DOF / Ag. Dir. Procurement
Pls advise me on this
without bank guarantee.
Thanks
12/12/22



UENR Official

R.T.O.

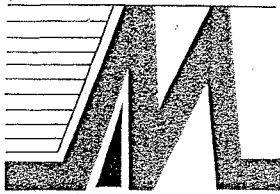

MAT-BANS COMPANY LTD.

Dealers in both Home & Office Furniture, Office Supplies and General Merchant

Our Ref..... Your Ref..... Date.....

7TH NOVEMBER, 2022

THE VICE CHANCELLOR
UNIVERSITY OF ENERGY & NATURAL RESOURCES
P.O.BOX 214
SUNYANI

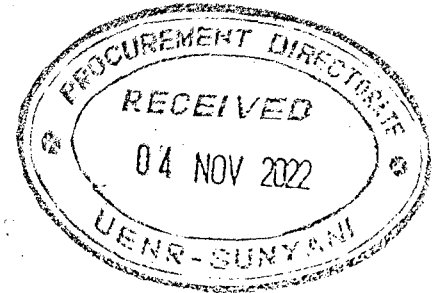

Dear Sir,

REQUEST FOR 15% MOBILIZATION FEE

With reference to your letter dated 11th October, 2022 with Ref. No. UENR/OVC/PROC/VOI.6/190/10/22 and we wish to request for 15% advance payment to enable us deliver the office furniture as per the contract.

The contract sum is Ghs 818,800.00 and therefore the 15% advance payment will be Ghs122, 820.00.

The request has become very necessary due to the current economic conditions as well as the fluctuation in our local currency against the United State Dollar.

We are counting on your usual co-operation.

Thank You.

Yours Faithfully,

NKANSAH G. ODAME

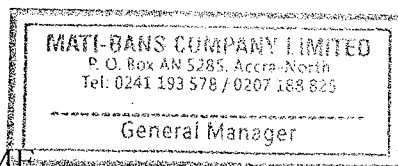

② As per am
please process
of 11/22



UNIVERSITY OF ENERGY AND NATURAL RESOURCES, SUNYANI
OFFICE OF THE VICE-CHANCELLOR

P. O. Box 214, Sunyani www.uenr.edu.gh +233 (0) 352 290 380 vc@uenr.edu.gh

OUR REF: UENR/OVC/PROC./VOL.6/190/10/22

DATE: OCTOBER 28, 2022

THE MANAGING DIRECTOR
 MAT-BANS COMPANY LIMITED
 ACCRA

[Handwritten Signature]
 VICE CHANCELLOR
 UNIVERSITY OF ENERGY &
 NATURAL RESOURCES
 SUNYANI

NOTIFICATION OF AWARD

BA/UENR/GD/006/22 (BA/UENR/RCEES/GD/007/22)

This comes to inform you that the University Entity Tender Committee (ETC) has awarded you the contract for the supply of (Lecture Hall Furniture) Item (s) below.

No	ITEM DESCRIPTION	SPECIFICATION	UNIT OF COUNT	QUANTITY	UNIT PRICE GH¢	TOTAL AMOUNT GH¢
	RCEES					
1	Lecture Hall Furniture	As captured in the Tender Documents and the Tenderer's Submission.	No.	Various	818,800.00	818,800.00
	Sub Total					818,800.00
	VAT (18.5%)					Inclusive
	Total Amount					818,800.00

1. Delivery: The order validity period is One Hundred and Twenty Days (120) Days. You are therefore expected to deliver the item(s) within eight (8) Weeks after signing the Contract. If the delivery is not effected by the said period, the contract may be deemed to have been cancelled and the contract will be re-awarded to the next evaluated bidder.

The goods would have to be delivered to the appropriate stores at the University on a working day within the hours of 8:30a.m and 4:00p.m. The University has the right to reject the goods if the goods are not delivered within the stipulated days and time.

The property and risk in the goods is transferred to the University and delivery completed by the supplier when the goods have been offloaded, delivered to the appropriate stores by the supplier and verified physically and technically by the appropriate staff of the University and certified with the appropriate documentation.

2. Payment Terms: Advance Payment of fifteen percent (15%) of the contract sum will be paid to the supplier after signing the contract. However, the remaining eighty-five percent (85%) of the



contract price shall be done in installments but not exceeding nine months after delivery to the supplier on receipt, inspection and acceptance of goods and the submission of your invoice.

3. You will be expected to pre - finance the contract.
4. The bulk of the goods when delivered must correspond with the sample/description.
5. An inspection team from the University will inspect the goods when delivered and it is upon their acceptance of the goods that you will be paid.
6. The prices agreed shall not be varied to the disadvantage of the University
7. The contract is non-severable therefore part delivery does not entitle you to payment.
8. You are to acknowledge your acceptance or otherwise of the terms and conditions of the award latest within two days after receipt of the award letter.

NOTE:

You are hereby instructed to do the following;

1. Provide Acceptance Letter for the above offer above within seven (7) days.
2. Provide of Performance Security/Bond as a percentage the Contract Sum [Ten (10) percent from a Bank or Thirty (30) percent from an Insurance Company].
3. There shall be signing of contract after all precondition have been met.
4. We strictly insist on the issuance of VAT invoice for all supplies.
5. For further clarification and directive, please contact the Director of Procurement-0244535464.

PLEASE NOTE: THE ITEM WILL BE REJECTED IF IT DOES NOT MEET OUR SPECIFICATION.

Authorized Signature.....



VICE CHANCELLOR
UNIVERSITY OF ENERGY &
NATURAL RESOURCES
SUNYANI

Name and Title of Signatory: Prof. Elvis Asare-Bediako, Vice-Chancellor

Cc: Pro Vice-Chancellor
Registrar
Director of Finance
Ag. Director of Procurement
Ag. Director, Internal Audit Directorate
Director, RCEES
Project Procurement Specialist
Project Financial Specialist -
Assistant Accountant, Stores
File





UNIVERSITY OF ENERGY AND NATURAL RESOURCES, SUNYANI
OFFICE OF THE PROCUREMENT DIRECTORATE

P. O. Box 214, Sunyani

www.uenr.edu.gh

+233 (0) 352 290 367

procurementdirector@uenr.edu.gh

Our Ref: PD/TO/NCT/0004/2023

Managing Director
Contra-Focus Limited
Accra

5th January, 2023

**S/NO. 2: PROCUREMENT OF FURNITURE FOR THE REGIONAL CENTRE FOR
ENERGY AND ENVIRONMENTAL SUSTAINABILITY (RCEES), UENR: LOT 2C:
LECTURE HALL FURNITURE
BA/UENR/GD/009/22 (BA/UENR/RCEES/GD/007/22)**

We write to express our appreciation for your participation in the above Procurement Package. We will encourage you to continually avail yourself in our subsequent request for tenders. However, you were not successful as recommendation for the package was made in favour of **Messrs Mat-Bans Company Limited** at an amount of *Eight Hundred and Eighteen Thousand, Eight Hundred Ghana Cedis only (GH¢818,800.00)*.

We wish you well in your future endeavours in this respect.

Thank you.

JOHN-BAPTIST SIDDICK, MCIPS
(AG. DIRECTOR OF PROCUREMENT)



UNIVERSITY OF ENERGY AND NATURAL RESOURCES, SUNYANI
OFFICE OF THE PROCUREMENT DIRECTORATE

P. O. Box 214, Sunyani

www.uenr.edu.gh

+233 (0) 352 290 367

procurementdirector@uenr.edu.gh

Our Ref: PD/TO/NCT/0005/2023

Managing Director
White Pleasure Company Limited
Accra

5th January, 2023

**S/NO. 2: PROCUREMENT OF FURNITURE FOR THE REGIONAL CENTRE FOR
ENERGY AND ENVIRONMENTAL SUSTAINABILITY (RCEES), UENR: LOT 2C:
LECTURE HALL FURNITURE
BA/UENR/GD/009/22 (BA/UENR/RCEES/GD/007/22)**

We write to express our appreciation for your participation in the above Procurement Package. We will encourage you to continually avail yourself in our subsequent request for tenders.

However, you were not successful as recommendation for the package was made in favour of **Messrs Mat-Bans Company Limited** at an amount of *Eight Hundred and Eighteen Thousand, Eight Hundred Ghana Cedis only (GH¢818,800.00)*.

We wish you well in your future endeavours in this respect.

Thank you.

JOHN-BAPTIST SIDDICK, MCIPS
(AG. DIRECTOR OF PROCUREMENT)



UNIVERSITY OF ENERGY AND NATURAL RESOURCES, SUNYANI
OFFICE OF THE VICE-CHANCELLOR

P. O. Box 214, Sunyani

www.uenr.edu.gh

+233 (0) 352 290 380

vc@uenr.edu.gh

OUR REF: UENR/OVC/PROC./VOL.6/190/10/22

DATE: OCTOBER 28, 2022

THE MANAGING DIRECTOR
 MAT-BANS COMPANY LIMITED
 ACCRA

[Handwritten Signature]
 VICE CHANCELLOR
 UNIVERSITY OF ENERGY &
 NATURAL RESOURCES
 SUNYANI

NOTIFICATION OF AWARD

BA/UENR/GD/006/22 (BA/UENR/RCEES/GD/007/22)

This comes to inform you that the University Entity Tender Committee (ETC) has awarded you the contract for the supply of (**Lecture Hall Furniture**) Item (s) below.

	ITEM DESCRIPTION	SPECIFICATION	UNIT OF COUNT	QUANTITY	UNIT PRICE GH¢	TOTAL AMOUNT GH¢
	RCEES					
1	Lecture Hall Furniture	As captured in the Tender Documents and the Tenderer's Submission.	No.	Various	818,800.00	818,800.00
	Sub Total					818,800.00
	VAT (18.5%)					Inclusive
	Total Amount					818,800.00

1. Delivery: The order validity period is One Hundred and Twenty Days (120) Days. You are therefore expected to deliver the item(s) within eight (8) Weeks, after signing the Contract. If the delivery is not effected by the said period, the contract may be deemed to have been cancelled and the contract will be re-awarded to the next evaluated bidder.

The goods would have to be delivered to the appropriate stores at the University on a working day within the hours of 8:30a.m and 4:00p.m. The University has the right to reject the goods if the goods are not delivered within the stipulated days and time.

The property and risk in the goods is transferred to the University and delivery completed by the supplier when the goods have been offloaded, delivered to the appropriate stores by the supplier and verified physically and technically by the appropriate staff of the University and certified with the appropriate documentation.

2. Payment Terms: Advance Payment of fifteen percent (15%) of the contract sum will be paid to the supplier after signing the contract. However, the remaining eighty-five percent (85%) of the



contract price shall be done in installments but not exceeding nine months after delivery to the supplier on receipt, inspection and acceptance of goods and the submission of your invoice.

3. You will be expected to pre - finance the contract.
4. The bulk of the goods when delivered must correspond with the sample/description.
5. An inspection team from the University will inspect the goods when delivered and it is upon their acceptance of the goods that you will be paid.
6. The prices agreed shall not be varied to the disadvantage of the University
7. The contract is non-severable therefore part delivery does not entitle you to payment.
8. You are to acknowledge your acceptance or otherwise of the terms and conditions of the award latest within two days after receipt of the award letter.

NOTE:

You are hereby instructed to do the following;

1. Provide Acceptance Letter for the above offer above within seven (7) days.
2. Provide of Performance Security/Bond as a percentage the Contract Sum [Ten (10) percent from a Bank or Thirty (30) percent from an Insurance Company].
3. There shall be signing of contract after all precondition have been met.
4. We strictly insist on the issuance of VAT invoice for all supplies.
5. For further clarification and directive, please contact the Director of Procurement-0244535464.

PLEASE NOTE: THE ITEM WILL BE REJECTED IF IT DOES NOT MEET OUR SPECIFICATION.

Authorized Signature.....



28/10/22

VICE CHANCELLOR
UNIVERSITY OF ENERGY &
NATURAL RESOURCES
SUNYANI

Name and Title of Signatory: Prof. Elvis Asare-Bediako, Vice-Chancellor

Cc: Pro Vice-Chancellor
Registrar
Director of Finance
Ag. Director of Procurement
Ag. Director, Internal Audit Directorate
Director, RCEES
Project Procurement Specialist
Project Financial Specialist
Assistant Accountant, Stores
File





UNIVERSITY OF ENERGY AND NATURAL RESOURCES, SUNYANI
OFFICE OF THE PROCUREMENT DIRECTORATE

P. O. Box 214, Sunyani

www.uenr.edu.gh

+233 (0) 352 290 367

procurementdirector@uenr.edu.gh

Our Ref: PD/TO/NCT/0006/2023

Managing Director
Yekna Investment Limited
Accra

5th January, 2023

**S/NO. 2: PROCUREMENT OF FURNITURE FOR THE REGIONAL CENTRE FOR
ENERGY AND ENVIRONMENTAL SUSTAINABILITY (RCEES), UENR: LOT 2C:
LECTURE HALL FURNITURE
BA/UENR/GD/009/22 (BA/UENR/RCEES/GD/007/22)**

We write to express our appreciation for your participation in the above Procurement Package. We will encourage you to continually avail yourself in our subsequent request for tenders. However, you were not successful as recommendation for the package was made in favour of **Messrs Mat-Bans Company Limited** at an amount of *Eight Hundred and Eighteen Thousand, Eight Hundred Ghana Cedis only (GH¢818,800.00)*.

We wish you well in your future endeavours in this respect.

Thank you.

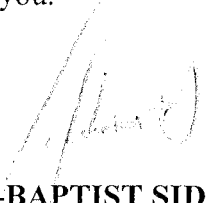
JOHN-BAPTIST SIDDICK, MCIPS
(AG. DIRECTOR OF PROCUREMENT)



REPUBLIC OF GHANA

**CENTRAL TENDER REVIEW
COMMITTEE (CTRC)**

**MINISTRY
OF
FINANCE**

P.O.Box MB 40, Ministries, Accra
Digital Address : GA-144-2024

Kindly quote this number and date on all correspondence

My Ref. No. CTRC/UENR.1/APP/M.19/2022

Your Ref. No. _____

Date. 25th October 2022

**RE: PROCUREMENT OF FURNITURE FOR THE REGIONAL CENTRE
FOR ENERGY AND DEVELOPMENTAL SUSTAINABILITY (RCEES),
UENR, LOT 2C: LECTURE HALL FURNITURE**

Please refer to the letter N°. UENR/OVC/PROC./VOL.6/189/10/22 and dated 18th October 2022, which was submitted on the above subject.

2. The Committee reviewed the University of Energy and Natural Resources' (UENR's) evaluation report at the 19th Sitting on Thursday, 27th October 2022. Based on documentation submitted, the Committee grants concurrent approval to UENR to engage the recommended tenderer, **Messrs Mat-Bans Company Limited** at a contract price of **Eight Hundred and Eighteen Thousand and Eight Hundred Ghana Cedis (GH¢818,800.00)** for completion in eight (8) weeks.
3. UENR will now proceed with the remaining procurement processes by giving notice of acceptance, signing a contract within the stipulated periods provided for in Section 65 (1) (2) of Act 663 and (Amendment) Act 914, and keeping records for future procurement audit.
4. Kindly note that failure of UENR to act in accordance with the above provision shall constitute a breach of the law.

DAVID QUIST
SECRETARY

**THE VICE CHANCELLOR
UNIVERSITY OF ENERGY AND
NATURAL RESOURCES
SUNYANI**

cc: The Hon. Minister, MOF
The Hon. Minister of State, MOF
The Hon. Deputy Ministers, MOF
The Chief Director, MOF
The Board Chairman, PPA
The Chief Executive, PPA
The Chairman, CTRC

UNIVERSITY OF ENERGY AND NATURAL RESOURCES, SUNYANI



**PROCUREMENT OF FURNITURE FOR THE REGIONAL CENTRE
FOR ENERGY AND ENVIRONMENTAL SUSTAINABILITY
(RCEES), UENR: LOT 2C: LECTURE HALL FURNITURE**

S/NO 2(LOT 2C)

BETWEEN

**UNIVERSITY OF ENERGY AND NATURAL RESOURCES,
SUNYANI (THE REGIONAL CENTRE FOR ENERGY AND
ENVIRONMENTAL SUSTAINABILITY, RCEES)**

AND

MAT-BANS COMPANY LIMITED

NOVEMBER, 2022

UNIVERSITY OF ENERGY AND NATURAL RESOURCES, SUNYANI
PROCUREMENT OF FURNITURE FOR THE REGIONAL CENTRE
FOR ENERGY AND ENVIRONMENTAL SUSTAINABILITY
(RCEES), UENR: LOT 2C: LECTURE HALL FURNITURE
BA/UENR/GD/006/22 (BA/UENR/RCEES/GD/007/22)

THIS AGREEMENT made on 4th day of November, 2022 between UNIVERSITY OF ENERGY AND NATURAL RESOURCES, Sunyani, Republic of Ghana (hereinafter called “the Purchaser”) of the one part and MAT-BANS COMPANY LIMITED of, Republic of Ghana (hereinafter called “the Supplier”) of the other part, items:

WHEREAS the Purchaser invited quotation for certain goods and ancillary services, viz,

No	ITEM DESCRIPTION	SPECIFICATION	UNIT OF COUNT	QUANTITY
	RCEES			
1	Procurement of Lecture Hall Furniture	As captured in the Tender Documents and the Tenderer’s Submission	No.	Various

as indicated in the tender document and has accepted a tender by the supplier for the **Procurement of Furniture for the Regional Centre for Energy and Environmental Sustainability (RCEES), UENR: Lot 2C: Lecture Hall Furniture** in the amount of **GH¢818,800.00 (Eight Hundred and Eighteen Thousand, Eight Hundred Ghana Cedis only)** (hereinafter called “the Contract Price”)

NOW THIS AGREEMENT WITNESSETH AS FOLLOWS:

1. In this Agreement words and expressions shall have the same meanings as are respectively assigned to them in the Conditions of Contract referred to.
2. The following documents shall be deemed to form and be read and construed as Part of this Agreement, viz.:
 - (a) The Tender Document submitted by the Supplier;
 - (b) The Schedule of Requirements;
 - (c) The Technical Specifications;
 - (d) The Conditions of Contract;
 - (f) The Purchaser’s Notification of Award; and
3. In consideration of the payments to be made by the Purchaser to the Supplier as hereinafter mentioned, the Supplier hereby covenants with the Purchaser to provide the goods and



UNIVERSITY OF ENERGY AND NATURAL RESOURCES, SUNYANI
OFFICE OF THE VICE-CHANCELLOR

P. O. Box 214, Sunyani

www.uenr.edu.gh

+233 (0) 352 290 380

vc@uenr.edu.gh

OUR REF: UENR/OVC/PROC./VOL.6/189/10/22

DATE: OCTOBER 18, 2022

THE SECRETARY
CENTRAL TENDER REVIEW
COMMITTEE (CTRC)
MINISTRY OF FINANCE
ACCRA.

Dear Sir,

SUBMISSION FOR CONCURRENT APPROVAL FOR THE AWARD OF CONTRACT:

PROCUREMENT OF FURNITURE FOR THE REGIONAL CENTRE FOR ENERGY AND ENVIRONMENTAL SUSTAINABILITY (RCEES), UENR: LOT 2A: OFFICE FURNITURE

PROCUREMENT OF FURNITURE FOR THE REGIONAL CENTRE FOR ENERGY AND ENVIRONMENTAL SUSTAINABILITY (RCEES), UENR: LOT 2C: LECTURE HALL FURNITURE

We submit to you the relevant documentations with respect to the above stated tenders for your review and approval since the proposed contracts amount exceeds the entity's threshold. The recommendation made by the Tender Evaluation Panel is summarized as follows:

CONTRACT NAME	PROPOSED TENDERER	PROPOSED CONTRACT AMOUNT
Procurement of Furniture for the Regional Centre for Energy and Environmental Sustainability (RCEES), UENR: Lot 2A: Office Furniture	Mat-Bans Company Limited	GH¢1,390,250.00
Procurement of Furniture for the Regional Centre for Energy and Environmental Sustainability (RCEES), UENR: Lot 2C: Lecture Hall Furniture	Mat-Bans Company Limited	GH¢818,800.00

Please find enclosed the following documents for your perusal.

- A copy of the Invitation for Tender - The Advertisement;
- 2 copies of Tender Documents;
- 5 copies of the Signed Evaluation Reports for the said contracts;
- Tenders Submitted by the Recommended Tenderers;



- Bank Statement from the Regional Centre for Energy and Environmental Sustainability (RCEES), UENR showing availability of funds for the procurement; and
- Procurement Plan (2022).

Your prompt action and approval would be very much appreciated.

Thank you for your usual cooperation.

Yours faithfully,



**VICE CHANCELLOR
UNIVERSITY OF ENERGY &
NATURAL RESOURCES
SUNYANI**

Prof. Elvis Asare-Bediako
VICE-CHANCELLOR

Cc: Ag. Pro-Vice-Chancellor
Registrar
Director of Finance
Ag. Internal Auditor
Director, RCEES
Secretary, Entity Tender Committee – UENR



Phoenix Insurance

Wisdom!

SURETY BOND

PERFORMANCE BOND

TYPE OF BOND : _____

BOND NUMBER : AC-11223199-DBPG-2200

OBLIGEE : UNIVERSITY OF ENERGY AND NATURAL SCIENCES
(OFFICE OF THE VICE CHANCELLOR)

PERIOD OF GUARANTEE : VALID FOR A PERIOD OF SIX (6) MONTHS

[IMPORTANT NOTICE: PLEASE SEE OVERLEAF FOR INFORMATION ON AUTHENTICATING THIS DOCUMENT]

HEAD OFFICE: 244/3, 6th Ringway Link Estate, Accra. **POSTAL ADDRESS:** P. O. Box 17753, Accra-Ghana.

TELEPHONE (+233-302) 246 322, 246 319, 246 644, 0243 690 492/3

WEBSITE: www.phoenixinsurancegh.com **EMAIL:** info@phoenixinsurancegh.com

KUMASI: (Main Office) Prempeh 1st Street (Opposite Intercity STC Bus Terminal) **TEL:** 032 20-49643 / **FAX:** 032 20-49640, Aseda House, Adum (near STC Bus Terminal) **TEL:** 032 20-37369

KUMASI BANTAMA: Adjacent Angel FM **TEL:** 0322087680 **SUNYANI:** Green Light Pharmacy House, First Floor, Bosoma High Street **TEL:** 03520 24520 / 27512

CAPE COAST: Behind the Science Faculty, UC **TEL:** 03320 90185 / 0208 113535. **TAKORADI:** CDH House, opp. Bank of Ghana, **TEL:** 0312 027 511

MADINA: Hse No EA 48/2 SDA Junction, Adenta-Accra **TEL:** 0302 545 617 **TEMA:** Meridian Plaza, Comm. 1 **TEL:** 0303 206431 **FAX:** 0303 210615

EAST LEGON: Prospect Court No. 100, Freetown Avenue, Papa's Pizza Building - Accra. (On the same building with Papa's Pizza) **TEL:** 0302 540 568

TAMALE: Bank of Ghana Road. same building with Airtel /Tigo office. **TEL:** 0372 027679. **TARKWA:** Effuanta, Opp. Methodist Church, **TEL:** 0205 019 075

HO AGENCY: Adjacent Nanatel, Ho main market road-Amegashie **Digital Address:** VH-0030-5717 **Contact Details:** Paschal Yawson **TEL:** 0247 958 635 / 0204 807 580

WA AGENCY: Main traffic NIB Road - Doodo street **Digital Address:** XW-0018-6471 **Contact Details:** Paschal Kanyi **TEL:** 0244 168 084/ 0247 525 987



BOND NO. AC-11223199-DBPG-2200

PERFORMANCE BOND

KNOW ALL MEN BY THESE PRESENTS that We, **MAT-BANS COMPANY LIMITED** of **P.O BOX AN 5285 ACCRA-NORTH** [hereinafter called "the CONTRACTOR"] and **PHOENIX INSURANCE COMPANY LIMITED** of **#244/3, 6TH LINK, RINGWAY ESTATES, ACCRA** [hereinafter called "the SURETY"] are held and firmly bound unto **UNIVERSITY OF ENERGY AND NATURAL RESOURCES, SUNYANI (OFFICE OF THE VICE CHANCELLOR)** of **SUNYANI** [hereinafter called "the PRINCIPAL"] in the sum of **GH¢245,640.00 (TWO HUNDRED AND FORTY-FIVE THOUSAND, SIX HUNDRED AND FORTY GHANA CEDIS)** for the payment of which sum, well and truly to be made, the Contractor and the Surety bind themselves, their successors and assigns, jointly and severally, firmly by these presents.

WHEREAS the Contractor has entered into a written contract agreement for **SUPPLY OF LECTURE HALL FURNITURE- BA/UENR/GD/006/22 (BA/UENR/RCEES/GD/007/22)** as per award letter dated **Thursday 3rd of November 2022** for a total contract sum of **GH¢818,800.00 (EIGHT HUNDRED EIGHTEEN THOUSAND EIGHT HUNDRED GHANA CEDIS)** to the extent therein provided for, are by reference made part hereof and are hereinafter referred to as the Contract.

NOW THE CONDITION of this bond is such that, if the Contractor shall promptly and faithfully perform the said Contract then this obligation shall be null and void; but on default by the Contractor during the period this Bond is in force the Surety shall satisfy and discharge the damages sustained by the Principal thereby up to the amount of the above written Bond

Whenever the Contractor shall be, and declared by the Principal to be, in default under the contract, the Principal having performed the Principal's obligations thereunder, the Surety may promptly remedy the default by:

- [1] Completing the Contract in accordance with its terms and conditions, or
- [2] Arranging for the services of the lowest responsible bidder for the Principal to complete the contract in accordance with its terms and conditions and make available to the principal as work progresses sufficient funds to pay the cost of completion less balance of the contract value not yet paid by the principal to the contractor; or
- [3] Paying the Principal the amount required by the Principal to complete the Contract in accordance with its terms and conditions any amount up to a total not exceeding the amount of this bond.

The Surety shall not be liable for a greater sum than the specified penalty of this Bond.

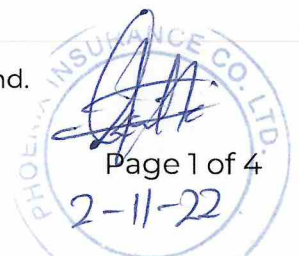

No right of action shall accrue on this Bond to or for the use of any person or corporation other than the Principal named herein or the Heirs, Executors, Administrators or successors of the Principal.

OTHER CONDITION: In case of any intended variation of the terms and conditions contained in the said Contract the Surety shall first be notified in writing and such variation shall if approved be accepted in writing by the Surety provided that all such variations or alterations not notified to the Surety shall release the Surety from any liability under this Bond.

This Bond shall be governed according to the laws of the Republic of Ghana.

This Bond shall be valid until the close of Business on the **Thursday 3rd of November 2022** and any claim arising thereunder must be notified to the surety in writing on or before that date after which it shall become void.

PERIOD OF BOND: VALID FOR A PERIOD OF SIX (6) MONTH(S) EFFECTIVE Wednesday 2nd of November 2022

SEALED with our respective Seals and dated this **Wednesday 2nd of November 2022**

Signed, Sealed for and on behalf of:

PHOENIX INSURANCE COMPANY LIMITED.

.....
MANAGING DIRECTOR

In the presence of: **SHEILA DASAH**

Witness: 
Date: **02/11/2022**

Signed, Sealed for and on behalf of:

MAT-BANS COMPANY LIMITED.

.....
MANAGING DIRECTOR

MAT-BANS COMPANY LTD.
P. O. BOX AV 5285, ACCRA-NORTH
MOBILE: 0241193578 / 0207188924

In the presence of:

Witness: 
Date: **03-11-2022**

REPUBLIC OF GHANA



**UNIVERSITY OF ENERGY AND NATURAL
RESOURCES (UENR), SUNYANI**

NATIONAL COMPETITIVE TENDERING (NCT)

IFT NO.: BA/UENR/GD/006/22 (BA/UENR/RCEES/GD/007/22)

***TENDER EVALUATION REPORT AND
RECOMMENDATIONS FOR AWARD OF CONTRACT FOR
PROCUREMENT OF FURNITURE FOR THE REGIONAL CENTRE FOR
ENERGY AND ENVIRONMENTAL SUSTAINABILITY (RCEES), UENR:
LOT 2C: LECTURE HALL FURNITURE***

S/NO 2(LOT 2C)

AUGUST, 2022

TABLE OF CONTENTS

<u>SECTION</u>		<u>PAGE</u>
1	Introduction.....	3
2	Standard Evaluation Forms.....	4
3	Method of Evaluation.....	5
4	Recommendation for Award of Contract.....	6
6	Standard Evaluation Forms for Items Being Evaluated.....	7
7	Annexes.....	47
	a. Register of Attendance at Tender Opening (for Tenderers' Representatives)	
	b. Register of Attendance at Tender Opening (for UENR Staff)	
	c. Tender Opening Recordings	
	d. Register of Tender Submissions	
	e. Advertisement	
	f. List of Tenderers Who Purchased Tender Document	
	g. Addendum to Advertisement	

1.0 INTRODUCTION

1.1 The University of Energy and Natural Resources (UENR), Sunyani through the Regional Centre for Energy and Environmental Sustainability (RCEES) intends to apply its Project Funds from World Bank to payments under the contract for the *Procurement of Furniture for the Regional Centre for Energy and Environmental Sustainability (RCEES), UENR: Lot 2C: Lecture Hall Furniture*, for which an invitation for tender was issued on the 31st August, 2022 in the Ghanaian Times News Paper (copy attached).

1.2 The University of Energy and Natural Resources (UENR), Sunyani issued the tender document through National Competitive Tendering under the guidelines of the Public Procurement Act, 2003 (Act 663) as amended for Supply of the underlisted item:

No.	Description	Quantity
1	Lecture Hall Furniture	Various

1.3 The submission and closing of tenders was at 11.00 am GMT on 20th September, 2022.

1.4 Tenders were opened at 11.00 am on Tuesday, 20th September, 2022. at the Council Chamber, Main Administration Block, UENR in the presence of tenderer's representatives who chose to attend.

1.5 At the tender opening, total tender prices, availability of Tender Securities and other information on eligibility were announced as shown in the attachments.

1.6 The list of tenders received is shown in **Table 1- Record of Tender Prices at Opening** for items being evaluated.

2.0 STANDARD EVALUATION FORMS

An Evaluation Panel was set up to evaluate and make recommendations for the award of contract. The Panel used the following **Standard Evaluation Forms**, as issued in the Public Procurement Act, 2003 (Act 663) as amended.

- a) **Table 1-** Record of Tender Prices at Opening
- b) **Table 2-** Preliminary Examination of Tenders
Table 2a- Commercial Responsiveness

Table 2b- Technical Responsiveness
- c) **Table 3-** Substantially Non-responsive Tenders
- d) **Table 4-** Correction, Conversion and Adjustment of Tender Prices
- e) **Table 5-** Exchange Rate
- f) **Table 6A-** Currency Conversion (Multiple Currencies)
(Not Applicable)
- g) **Table 6B-** Currency Conversion (Single Currency)
- h) **Table 7-** Additions, Unconditional Discounts
- i) **Table 8A-** Domestic Preference for Goods **(Not Applicable)**
- j) **Table 8B-** Domestic Preference for Works **(Not Applicable)**
- k) **Table 9-** Postqualification
- h) **Table 10-** Proposed Contract Award

3.0 **METHOD OF EVALUATION**

The Evaluation Panel adopted a two-stage evaluation method in identifying the lowest evaluated responsive tenderer. These were Preliminary Examination under **Table 2 (note Table 2 is a Summary of Table 2a and 2b)**, and Detailed Price Examination under **Tables 4 & 7**.

3.1 **Preliminary Examination**

3.1.1 The following details were verified to ascertain their correctness.

- i. Signed Tender Form
- ii. Delivery Period

- iii Cost, Insurance, Paid (CIP) UENR, Sunyani.
- iv. Responsiveness to the Technical Specifications
- v. Other conditions indicated in the Invitation to Tenders

3.1.2 The information available in each tender was verified to identify and eliminate those which were found to be incomplete, invalid or substantially non-responsive to the terms and conditions in the tender document.

3.1.3 The findings were summarised on **Table 2**. A "**Yes**" stands for tenders which have met the terms and conditions requested for in the tender document, while a "**No**" stands for non compliance.

3.1.4 Tenders with deviations from the minimum conditions were declared non responsive. (**Refer to Table 2, Table 2a and 2b**). Those tenders declared responsive in Table 2 were passed on to **Table 4 and 7-** Detailed Examination.

3.2 Detailed Examination

3.2.1 Under detailed examination price verification was carried out to identify discrepancies between unit and total prices. Corrections were made accordingly on Table 4. Where additions are detected in the tenders, Table 7- Additions, Unconditional Discounts is applied.

4.0 RECOMMENDATION FOR AWARD OF CONTRACT

On the basis of the evaluation (outlined in this Report), which was carried out in accordance with the Tender Document, we recommend accepting the tender for the lowest evaluated responsive tenderer and which has been determined as qualified and capable of performing the Contract below.

Standard Tender Evaluation Forms

For

**PROCUREMENT OF FURNITURE FOR THE REGIONAL CENTRE FOR ENERGY AND
ENVIRONMENTAL SUSTAINABILITY (RCEES), UENR:
LOT 2C: LECTURE HALL FURNITURE**

S/NO 2(LOT 2C)

Summary Evaluation Data & Award Recommendations





1. Project Name: S/NO. 2: Procurement of Furniture for the Regional Centre for Energy and Environmental Sustainability (RCEES), UENR: Lot 2C: Lecture Hall Furniture
 2. Contract Name: S/NO. 2: Procurement of Furniture for the Regional Centre for Energy and Environmental Sustainability (RCEES), UENR: Lot 2C: Lecture Hall Furniture
- Contract Number: IFT NO.: BA/UENR/GD/006/22 (BA/UENR/RCEES/GD/007/22)**
3. Tender Opening Date: 20th September, 2022 at 11.00 am

4. TENDER EVALUATION SUMMARY

No.	Tenderer	Read Out Tender Price	Converted to Common Currency	Substantially Responsive (Yes or No)	Evaluated Tender Price	Rank	Remarks
1	White Pleasure Company Limited	1,054,706.63	GH¢	NO	N/A	N/A	
2	Mat-Bans Company Limited	818,800.00	GH¢	YES	818,800.00	1 ST	Recommended
3	Contra-Focus Limited	880,238.00	GH¢	NO	N/A	N/A	
4	Yekna Investment Limited	1,707,576.00	GH¢	NO	N/A	N/A	

5. The lowest evaluated tenderer has been determined to be qualified and capable of performing the contract.
6. On the basis of the evaluation (outlined in the attached Report), which was carried out in accordance with the Tender Documents, we recommend accepting the tender of the lowest evaluated tenderer, **Mat-Bans Company Limited**, which has been determined as qualified and capable of performing the Contract for the **Procurement of Furniture for the Regional Centre for Energy and Environmental Sustainability (RCEES)**, UENR: Lot 2C: Lecture Hall Furniture at a contract price of GH¢818,800.00 to be delivered within 8 weeks after signing of contract.

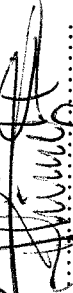
EVALUATION PANEL

Name	Designation	Signature	Date
Prof. Simon Abugre	Chairman		17/10/2022
Mr. John-Baptist Siddick	Member		17/10/2022
Mr. Paul Nana Nketiah	Member		18/10/2022
Mr. Kwaku Obeng Mireku	Member		18/10/2022
Mr. Kofi Dwomoh	Secretary		17/10/2022

FORM 1

Project: **S/NO. 2: Procurement of Furniture for the Regional Centre for Energy and Environmental Sustainability (RCEES), UENR: Lot 2C: Lecture Hall Furniture**

Contract: **S/NO. 2: Procurement of Furniture for the Regional Centre for Energy and Environmental Sustainability (RCEES), UENR: Lot 2C: Lecture Hall Furniture**

The following tenders were received by the tender closing deadline fixed at **11.00 am on 20th September, 2022** and were immediately opened thereafter.

Table 1. Record of Tender Prices (as read out) at Opening

No	Tenderer Identification			Read-Out Tender Prices		Modifications or Comments or Discounts (g)
	Name (b)	Address (c)	Nationality (d)	Currency (e)	Amounts (f)	
1	White Pleasure Company Limited	P.O. BOX OS 250, OSU-ACCRA	Ghanaian	GH¢	1,054,706.63	Nil
2	Mat-Bans Company Limited	P.O. BOX AN 5285, ACCRA-NORTH	Ghanaian	GH¢	818,800.00	Nil
3	Contra-Focus Limited	P.O. BOX 20051, ACCRA	Ghanaian	GH¢	880,238.00	Nil
4	Yekna Investment Limited	P.O. BOX AT 125, ACHIMOTA-ACCRA	Ghanaian	GH¢	1,707,576.00	Nil

Table 2. Preliminary Examination

No.	Tenderer	Verification*	Eligibility**	Tender Security*** (2% of Tender Price)	Completeness of Tender****	Substantial***** Responsiveness	Acceptance for Detailed Examination
	(a)	(b)	(c)	(d)	(e)	(f)	(g)
1	White Pleasure Company Limited	YES	YES	YES	YES	YES	YES
2	Mat-Bans Company Limited	YES	YES	YES	YES	YES	YES
3	Contra-Focus Limited	YES	YES	YES	YES	YES	YES
4	Yekna Investment Limited	YES	YES	YES	YES	YES	YES

* Signed Tender Form & Price Schedule; Manufacturer's Authorization

** Valid Business Registration Certificate; Valid Tax Clearance Certificate; VAT Registration Certificate; Valid SSNIT Certificate

***Tender Security (2% of Tender Price; from a recognized bank or Insurance Company; valid 28 days beyond tender validity date

**** No partial tenders; No Erasures, additions or other changes not initialed; No missing pages in the original tender; Qualification Information provided

*****No price variation from original; No different specifications from original; No phasing of contract

Table 2 (a). Preliminary Examination (Commercial Responsiveness)

No.	Tenderer	Delivery Period (8 Weeks after contract signing)	Payment Terms (Payments shall be done in installments but not exceeding nine months after delivery)	Tender Validity Period (120 Days)	Audited Accounts (2020 and 2021)	List of at least 3 users who have purchased similar Furniture in the last 2 years	INCOTERMS [Delivery to Site - CIP]	Commercially Responsive (YES/NO)	Acceptance for Detailed Examination
	(a)	(b)	(c)	(d)	(e)	(g)	(h)	(i)	(j)
1	White Pleasure Company Limited	YES	YES	YES	YES	YES	YES	YES	YES
2	Mat-Bans Company Limited	YES	YES	YES	YES	YES	YES	YES	YES
3	Contra-Focus Limited	YES	YES	YES	YES	NO	YES	NO	NO
4	Yekna Investment Limited	YES	NO	YES	NO	YES	YES	NO	NO

Table 2 (b). Preliminary Examination (Technical Responsiveness)

**S/NO. 2: Procurement of Furniture for the Regional Centre for Energy and Environmental Sustainability (RCEES), UENR:
Lot 2C: Lecture Hall Furniture**

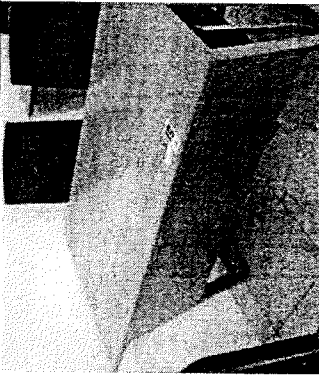
No.	Minimum Specifications Required	Quantity	Offered Specification	
	<p>PRINCIPAL FEATURES SOUGHT:</p>		White Pleasure Company Limited	Mat-Bans Company Limited
	<p>LECTURE HALL A GROUND FLOOR</p>			
1	<p>2 In 1 Tables with Stationary Chairs: Standard Straight Desk, Legs made of aluminum, Smooth surface, Polished Wood, Durable and comfortable for lecture hall, Dimension 1.6M in length</p>	<p>18 No.</p>	<p>Not Comply</p>	<p>Comply</p>
			<p>Not Comply</p>	<p>Comply</p>
2	<p>Single Table With Metal Legs: Standard Straight Desk, Legs made of aluminum, Smooth surface, Polished Wood, Durable and comfortable for lecture hall, Dimension 1.0M in length</p>	<p>6 No.</p>	<p>Not Comply</p>	<p>Comply</p>

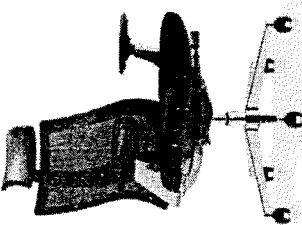
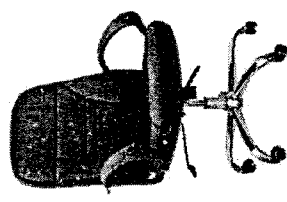

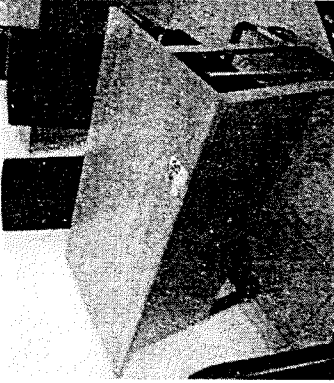
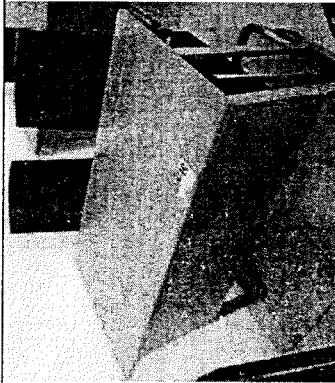
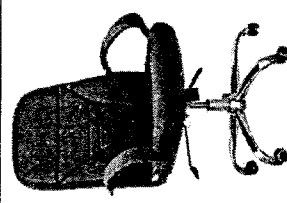
3	Lecturer Table: Standard Straight Desk, Legs made of aluminum, Smooth surface, Polished Wood, Durable and comfortable for lecture hall, Dimension 1.4M in length, Movable Table	4 No.	Not Comply	Comply
4	Lecturer Swivel Chair: Black Vinyl Upholstery Seat with Passive Lumbar support Pneumatic Seat Height Adjustment, Black Nylon Loop Arms Heavy-Duty Nylon Base, Dual Wheel Carpet Casters, Dimensions: Overall: 41"-45"(H), Seat Size: 20" (W)X 19.5" (D), Seat height: 17"-21"H, Back Size: 20" (W) X 26" (H), Finish: Black /Brown, Black Nylon Loop Arms Heavy-Duty Nylon Base, Adjustable Handle with Mesh Back	4 No.	Not Comply	Comply
			Not Comply	Comply
5	Swivel Chairs: Leather Swivel chair, PU upholstery front back and seat, PVC backing, Black Nylon Loop Arms Heavy-Duty Nylon Base, Dual Wheel Carpet Casters, Durable and Comfortable, Plastic Handle, Adjustable Height, Colour: Black	42 No.	Not Comply	
			Not Comply	
1 ST FLOOR LECTURE HALL B				
6	2 In 1 Desk: Standard Straight Desk, Legs made of aluminum, Smooth surface, Polished Wood, Durable and comfortable for lecture hall, Dimension 1.6M in length	17 No.	Not Comply	Comply

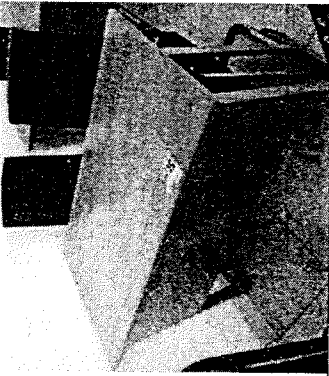
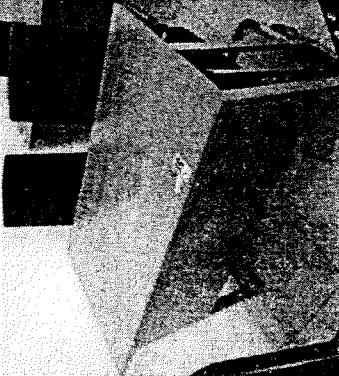
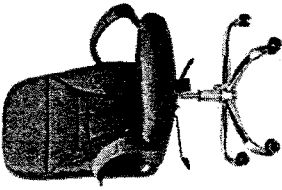
				Not Comply	Comply
7	Single Desk: Standard Straight Desk, Legs made of aluminum, Smooth surface, Polished Wood, Durable and comfortable for lecture hall, Dimension 1.0M in length		3 No.	Not Comply	Comply
8	Swivel Chair: Leather Swivel chair, PU upholstery front back and seat, PVC backing, Black Nylon Loop Arms Heavy-Duty Nylon Base, Dual Wheel Carpet Casters, Durable and Comfortable, Plastic Handle, Adjustable Height, Colour: Black		37 No.	Not Comply	Comply
				Not Comply	Comply
1 ST FLOOR LECTURE HALL C					
9	2 In 1 Desk: Standard Straight Desk, Legs made of aluminum, Smooth surface, Polished Wood, Durable and comfortable for lecture hall, Dimension 1.6M in length		17 No.	Not Comply	Comply

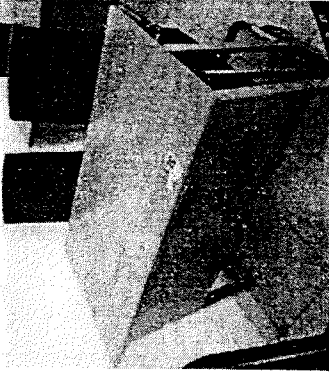
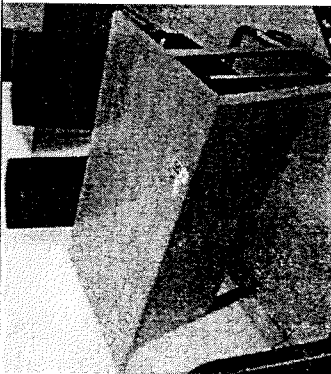
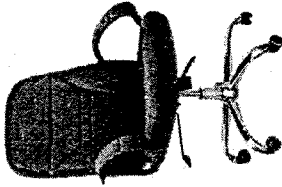
					Not Comply	Comply
10	Single Desk: Standard Straight Desk, Legs made of aluminum, Smooth surface, Polished Wood, Durable and comfortable for lecture hall, Dimension 1.0M in length		3 No.		Not Comply	Comply
					Not Comply	Comply
11	Swivel Chair: Leather Swivel chair, PU upholstery front back and seat, PVC backing, Black Nylon Loop Arms Heavy-Duty Nylon Base, Dual Wheel Carpet Casters, Durable and Comfortable, Plastic Handle, Adjustable Height, Colour: Black		37 No.		Not Comply	Comply
					Not Comply	Comply
1ST FLOOR LECTURE HALL – D						
12	2 In 1 Desk: Standard Straight Desk, Legs made of aluminum, Smooth surface, Polished Wood, Durable and comfortable for lecture hall, Dimension 1.6M in length		18 No.		Not Comply	Comply

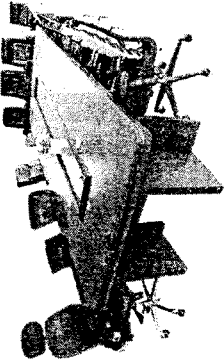
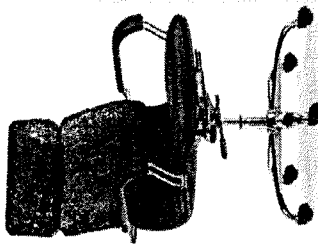
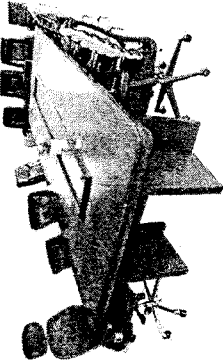

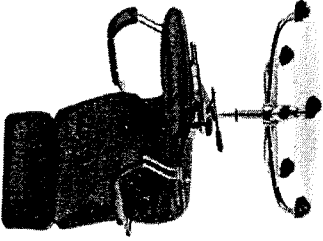
				Not Comply	Comply
13	Single Desk: Standard Straight Desk, Legs made of aluminum, Smooth surface, Polished Wood, Durable and comfortable for lecture hall, Dimension 1.0M in length	6 No.		Not Comply	Comply
				Not Comply	Comply
14	Swivel Chair: Leather Swivel chair, PU upholstery front back and seat, PVC backing, Black Nylon Loop Arms Heavy-Duty Nylon Base, Dual Wheel Carpet Casters, Durable and Comfortable, Plastic Handle, Adjustable Height, Colour: Black	42 No.		Not Comply	Comply
				Not Comply	Comply
SEMINAR ROOM A- GROUND FLOOR					
15	14 Seater Conference Table with Chairs: Executive design, 6 Meters dimensions, Rectangular is shape, Coffee in colour, Durable Wooden Table, Special Feature Suitable for Office, Computer, Laptop , General use	1 No.		Not Comply	Comply

				Comply
16	Swivel Chairs: Leather Swivel chair, PU upholstery front back and seat, PVC backing, Chromed sleight frame, Head Rest Support, Adjustable Height, Durable and Comfortable for long hour of meeting, Padded leather Handle, Seat height: 17"-21"H, Back Size: 20" (W) X 26" (H), Colour: Black		14 No.	Comply
				Comply
SEMINAR ROOM B- GROUND FLOOR				
17	14 Seater Conference Table With Chairs: Executive design, 6 Meters dimensions, Rectangular is shape, Coffee in colour, Durable Wooden Table, Special Feature Suitable for Office, Computer, Laptop , General use		1 No.	Comply
				Comply
18	Swivel Chairs: Leather Swivel chair, PU upholstery front back and seat, PVC backing, Chromed sleight frame, Head Rest Support, Adjustable Height, Durable and Comfortable for long hour of meeting, Padded leather Handle, Seat height: 17"-21"H, Back Size: 20" (W) X 26" (H), Colour: Black		14 No.	Comply

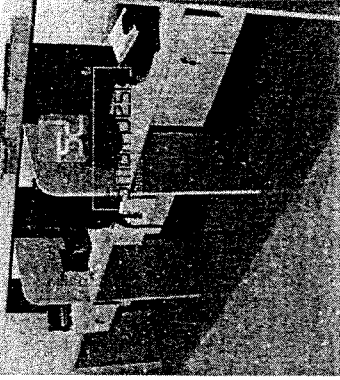
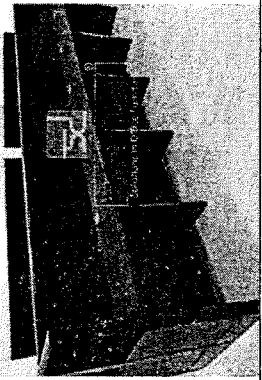
			Not Comply	Comply
PHD STUDY ROOM				
19	<p>4 Seater Workstation: 4 Seater Straight workstation with Cabinets, 1.0M dimension per student, Wooden Cabinet fit to the wall for storage, Durable laminate construction is stain and scratch resistant Easy assembly (assembles in under 30 minutes), Locking pedestals can be configured left or right, Box-frame legs are constructed of 14-gauge steel, Polished Surface, Surface is 0.6M, Thickness Partition: 4.5CM, Has Electronic holes for laptop and desktop computers, printers etc</p> 	5 No.	Not Comply	Comply
20	<p>5 Seater Workstation (1.0M): 4 Seater Straight workstation with Cabinets, 1.0M dimension per student, Wooden Cabinet fit to the wall for storage, Durable laminate construction is stain and scratch resistant, Easy assembly (assembles in under 30 minutes), Locking pedestals can be configured left or right, Box-frame legs are constructed of 14-gauge steel, Polished Surface, Surface is 0.6M, Thickness, Partition: 4.5CM, Has Electronic holes for laptop and desktop computers, printers etc</p> 	5 No.	Not Comply	Comply
21	<p>7-Seater Workstation (1.0M): 7-Seater Straight workstations with Cabinets, 1.0M dimension per student, Wooden Cabinets fit to the wall for storage, Durable laminate construction is stain and scratch resistant, Easy assembly (assembles in under 30 minutes), Locking pedestals can be configured left or right, Box-frame legs are constructed of</p>	2 No.	Not Comply	Comply

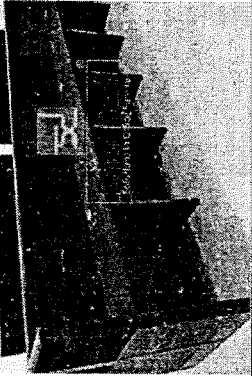
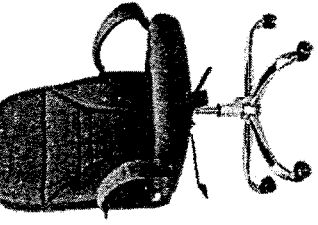
	14-gauge steel, Polished Surface, Surface is 0.6M, Thickness Partition: 4.5CM, Has Electronic holes for laptop and desktop computers, printers etc			Not Comply	Comply
					
MASTERS STUDY HALL					
22	4 Seater Workstation: 4 Seater Straight workstation with Cabinets, 1.0M dimension per student, Wooden Cabinet fit to the wall for storage, Durable laminate construction is stain and scratch resistant Easy assembly (assembles in under 30 minutes), Locking pedestals can be configured left or right, Box-frame legs are constructed of 14-gauge steel, Polished Surface, Surface is 0.6M, Thickness Partition: 4.5CM, Has Electronic holes for laptop and desktop computers, printers etc		10 No.	Not Comply	Comply
				Not Comply	Comply
23	5 Seater Workstation (1.0M): 4 Seater Straight workstation with Cabinets, 1.0M dimension per student, Wooden Cabinet fit to the wall for storage, Durable laminate construction is stain and scratch resistant, Easy assembly (assembles in under 30 minutes), Locking pedestals can be configured left or right, Box-frame legs are constructed of 14-gauge steel, Polished Surface, Surface is 0.6M, Thickness Partition: 4.5CM, Has Electronic holes for laptop and desktop computers, printers etc		2 No.	Not Comply	Comply

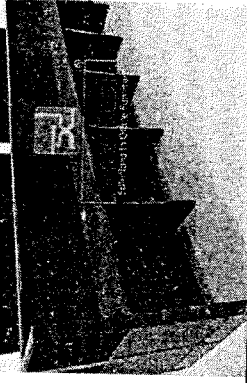
			Not Comply	Comply
24	<p>7-Seater Workstation (1.0M): 7-Seater Straight workstations with Cabinets, 1.0M dimension per student, Wooden Cabinets fit to the wall for storage, Durable laminate construction is stain and scratch resistant, Easy assembly (assembles in under 30 minutes), Locking pedestals can be configured left or right, Box-frame legs are constructed of 14-gauge steel, Polished Surface, Surface is 0.6M, Thickness Partition: 4.5CM, Has Electronic holes for laptop and desktop computers, printers etc</p>	2 No.	Not Comply	Comply
			Not Comply	Comply
PHD and Masters Study Hall				
25	<p>Swivel Chair: Black Vinyl Upholstery Seat with Passive Lumbar support Pneumatic Seat Height Adjustment, Black Nylon Loop Arms Heavy-Duty Nylon Base, Dual Wheel Carpet Casters, Dimensions: Overall: 41"-45"(H), Seat Size: 20" (W)X 19.5"(D), Seat height: 17"-21"H, Back Size: 20" (W) X 26" (H), Finish: Black /Brown, Black Nylon Loop Arms Heavy-Duty, Nylon Base</p>	80 No.	Not Comply	Not Comply
			Not Comply	Comply
LIBRARY HALL				

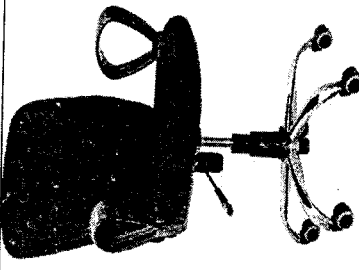
26	<p>Metal With Wood Curve Workstation: Executive design, 14 Meters dimensions, Curve is shape, Coffee in colour, Durable Wooden Table, Partition of 1.0M per student</p> 	9 No.	Not Comply	Comply
27	<p>20 Seating Capacity Library Tables: Executive design, 14 Meters dimensions, Rectangular is shape, Coffee in colour, Durable Wooden Table, Partition of 1.0M per student</p> 	11 No.	Not Comply	Comply
28	<p>Library Swivel Chair: Office Swivel Chair, Black Vinyl Upholstery seat with Passive Lumber support Pneumatic Seat Height Adjustment, Black Nylon Loop Arms Heavy-Duty Nylon Base, Dual Wheel Carpet Casters, Arm rest</p> 	20 No.	Not Comply	Comply
29	<p>Metal Library Bookshelves: High quality cold-rolled plate, Hardness to meet the load bearing requirement, Flexible combination, Scientific division, User --Friendly design, Anti-corrosion moisture, Easy to install and remove, simple and convenient</p>	5 No.	Not Comply	Comply

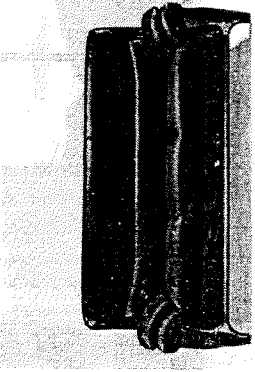
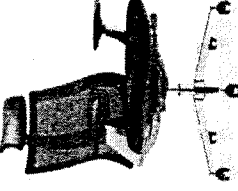
				Comply
30	<p>3 In 1 Sofa</p>	<p>1 No.</p>	<p>Not Comply</p>	Comply
			<p>Not Comply</p>	Comply
31	<p>Executive Swivel Chair: Executive Mesh Swivel Chair, Black Vinyl Upholstery seat with Passive Lumber support Pneumatic Seat Height Adjustment, Black Nylon Loop Arms Heavy-Duty Nylon Base, Dual Wheel Carpet Casters, Arm rest and head rest, Adjustable handle, Dimension: 22.5" x 22" 33H</p>	<p>1 No.</p>	<p>Not Comply</p>	Comply
			<p>Not Comply</p>	Comply
32	<p>Visitor Chair: Fully upholstered in high grade black Mesh, Chrome base and chrome arms (metal arms), Seat Height: (min-max) 450mm-530mm, Back width X Height: Medium Back 520 x 580mm, Back Width x Height High back: 520mm x 700mm, Seat Width x Depth: 520mm, Seat Width x Depth: including arms: 630mm</p>	<p>4 No.</p>	<p>Not Comply</p>	Comply

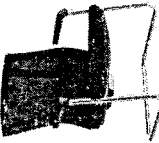
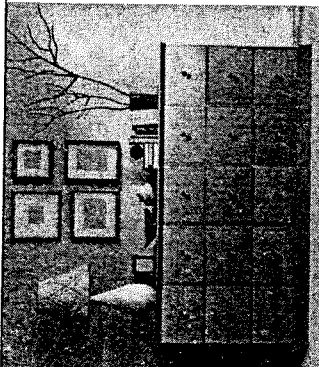
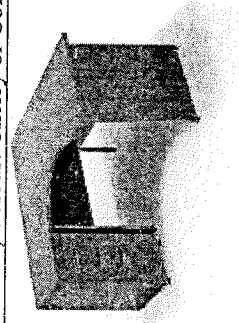
			Not Comply	Comply
33	<p>24 Pigeon Holes Cabinet: Metal shelves into cube size, Partition into 24 holes, Key lock for every hole, Each hole is 17 x 17 inches, Durable and Executive in nature, Suitable for a Library</p> 	1 Set	Not Comply	Comply
34	<p>Executive 1.6M Desk: Executive L-Shaped Office Desk With Chest of Drawers, L-Shaped and drawers are movable, Padded writing space, Material Make: Made of Hard Chip, First Grade, Polished wood with smooth surface, Durable, Colour: Cherry or Coffee, Size: 1.6M</p> 	1 No.	Not Comply	Comply
35	<p>Swivel Chair: Office Mesh Swivel Chair, Black Vinyl Upholstery seat with Passive Lumber support Pneumatic Seat Height Adjustment, Black Nylon Loop Arms Heavy-Duty Nylon Base, Dual Wheel Carpet Casters, Arm and Head rest, Dimension: 22.5" x 22" 33H</p>	1 No.	Not Comply	Comply

				Comply
<i>Deviations from Minimum Technical Specifications</i>				
<i>Acceptance for Detailed Examination</i>				
			Yes	Nil
			No	Yes

Table 3. Substantially Non-responsive Tenders

No	Tender	Reasons for Rejection
1	White Pleasure Company Limited	The firm was disqualified at the Technical Responsiveness Stage because the firm's proposed Lecture Hall Furniture did not meet our Technical Requirements.
2	Contra-Focus Limited	The firm was disqualified at the Commercial Responsiveness Stage because the List of References they provided were not related to Office Furniture.
3	Yekna Investment Limited	<p>The firm was disqualified at the Commercial Responsiveness Stage because of the following reasons;</p> <ul style="list-style-type: none"> • They did not provide information on the Payment Terms requirement as requested. • They did not Audited Financial Accounts for 2020 and 2021 as requested.

FORM 4

Table 4 Corrections and Unconditional Discounts

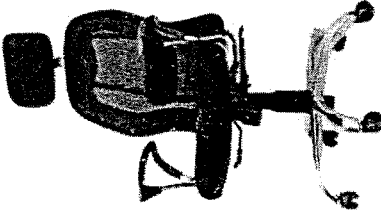
No.	Tenderer	Read-out Tender Price(s)		Corrections		Corrected Tender Price(s)	Unconditional Discounts ²		Corrected/Dis counted Tender Price
		Currency	Amount	Computational Errors	Provisional Sums		%	Amount	
	(a)	(b)	(c)	(d)	(e)	(f) = (c) + (d) - (e)	(g)	(h)	(i) = (f) - (h)
1	Mat-Bans Company Limited	GH¢	818,800.00	NIL	NIL	GH¢818,800.00	NIL	NIL	GH¢818,800.00

Table 5. Exchange Rates

Currency Used for Tender Evaluation: **GHANA CEDI**

Effective Date of Exchange Rate: N/A

Authority or Publication Specified for Exchange Rate: N/A

Note: Attach copy of exchange rates provided by specified authority or publication.

Table 6A. Currency Conversion (Multiple Currencies)

Specify Evaluation Currency: _____

N/A FOR THIS TENDER

Tenderer (a)	Currency(ies) of Tender (b)	Corrected/Discounted Tender Price(s) (c)	Applicable Exchange Rate(s) ¹ (d)	Evaluation Currency	
				Tender Price(s) <i>(e) = (c) x (d)</i>	Total Tender Price ² <i>(f)</i>

Note: Columns *a*, *b* and *c* are from Table 4, columns *a*, *b* and *i*.

¹ Column *d* is from Table 5.

² Column *f* is the sum of Tender prices in column *e* for each Tenderer.

Table 6B. Currency Conversion (Single Currency)
Specify Evaluation Currency: **GHANA CEDI**

N/A FOR THIS TENDER

Tenderer	Corrected/Discounted Tender Price (in specified currency)	Payment Composition ¹		Exchange Rate Used by Tenderer ¹	Amounts in Currency of Payment	Exchange Rate for Evaluation ²	Evaluation Currency	
		Currency of Payment	Percent of Total Tender				Tender Prices	Total ³
(a)	(b)	(c)	(d)	(f)	(g) = (e) x (f)	(h)	(i) = (g) x (h)	(i)

Note: Columns *a* and *b* are from Table 4, columns *a* and *i*.

¹ Columns *c*, *d*, and *f* are provided in the STDL.W Appendix to Tender and in the (Form of) Contractor's Tender in the STDSW.
² Column *h* is from Table 5.

³ Column *j* is the sum of Tender prices in column *i* for each Tenderer.

Table 7. Additions, Adjustments, and Priced Deviations

No.	Tenderer	Corrected/Discounted Tender Price¹	Additions²	Adjustments²	Priced Deviations²	Total Price
	(a)	(b)	(c)	(d)	(e)	(f) = (b) + (c) + (d) + (e)
1	Mat-Bans Company Limited	GH¢818,800.00	NIL	NIL	NIL	GH¢818,800.00

Column *b* is from either Table 8, column *f* or Table 9, column *j*.

² Each insertion in columns *c*, *d*, or *e* should be footnoted and explained in adequate detail, accompanied by calculations. Refer to paras. 6(e), 6(f), and 6(g) respectively of the Guidance Notes on Opening & Evaluation of Tenders.

Table 8A. Domestic Preference for Goods
Specify Evaluation Currency: _____

N/A FOR THIS TENDER

Tenderer	Domestic Preference Group ¹	Total Price ²	Exclusions for Preference ³	Revised Total	Prevailing Tariff (%) ⁴	Domestic Preference (%) ⁵	Preference Price ⁶	Total Comparison Price
(a)	(b)	(c)	(d)	(e) = (c) - (d)	(f)	(g)	(h)	(i) = (c) + (h)

- ¹ Column *b* refers to Groups A, B, or C, as indicated by Tenderer, subject to verification by the Evaluation Panel.
- ² Column *c* is from Table 7, column *f*. If the lowest total price is from a Group A or Group B Tenderer, it is the lowest evaluated Tenderer, and the remainder of the table need not be filled out. Columns *d* through *h* need to be filled out only for Group C Tenders.
- ³ Column *d* is the sum of costs in columns *d* and *e* from Table 7 plus other costs incurred within Ghana. Footnotes should be provided to explain the significant components of column *d*.
- ⁴ Column *f* is the sum of duties and import taxes on the particular items or group of similar items as a percent of the CIF or CIP price. Refer to para. 7(a) of the Guidance Notes on Opening & Evaluation of Tenders.
- ⁵ Column *g* will be the smaller of 20 percent or the prevailing tariff in column *f*.
- ⁶ Column *h* for Group A Tenderers is zero. Group B Tenderers at this stage should no longer be compared. For Group C Tenderers, column *h* is the product of columns *e* and *g*.

Table 8B. Domestic Preference for Works

Specify Evaluation Currency: _____

N/A FOR THIS TENDER

Tenderer	Domestic Preference Group ¹ (b)	Total Price ² (c)	Exclusions for Preference ³ (d)	Revised Total (e) = (c) - (d)	Preference 4 f	Total Comparison Price (g) = (c) + (f)
(a)						

¹ Column b refers to Group A (eligible domestic Tenderers) or Group B (others) as indicated by Tenderer, subject to verification the Evaluation Panel.

² Column c is from Table 7, column f. If the lowest priced Tender is from a Group A Tenderer, it is the lowest evaluated Tenderer, and the remainder of the table need not be filled out.

³ Column d is the sum of costs in columns d and e from Table 7. An attachment should be provided to explain the significant components of column d. Columns d and e may be left blank for Group A Tenderers.

⁴ Column f for Group A Tenderers is zero. For Group B Tenderers, column f is 10 percent of column e.

Table 9. Postqualification

Tenderer	Constitution or legal status of Tenderer	Total annual volume of supplies made in the last two years in GH¢:	Supplies performed as prime Supplier on works of similar nature and volume over the last two years.	Financial reports for the last two years	Names, addresses and telephone, telex, facsimile numbers and email addresses of banks that may provide references if contacted by the Purchaser.	Information on current litigation in which the Tenderer is involved	Substantially Responsive/ Non-Responsive ² to Postqualification Criteria	Remarks
MAT-BANS COMPANY LIMITED	(a) 1. Place of registration: <i>Accra</i> 2. Date of registration: <i>05-08-2014</i> 3. Principal place of business: <i>Accra</i> 4. Power of attorney of signatory of Tenderer: <i>Provided</i>	(b) YES Provided	(c) YES Provided	(d) YES Provided	(e) N/A	(f) NO Not involved in any litigation.	(g) Substantially Responsive to Post qualification Criteria	(h)

¹ List here all the Qualifying Criteria for Postqualification provided in the Tender Documents, which Tenderers must comply with for their them to be considered for Contract Award. For each criteria, indicate “yes” for satisfactory and “no” for unsatisfactory

² Give reason(s) for substantial responsiveness as footnote(s)

Table 10: Proposed Contract Award

1. Lowest evaluated responsive Tenderer (proposed for contract award). (a) name (b) address	MAT-BANS COMPANY LIMITED P.O. BOX AN 5285, ACCRA-NORTH	
2. If Tender submitted by agent, list actual supplier. (a) name (b) address	Not Applicable	
3. If Tender from joint venture, list all partners, nationalities, and estimated shares of contract.	Not Applicable	
4. Principal country of origin of goods/materials.	China	
5. Estimated date (month, year) of contract signing.	November, 2022	
6. Estimated delivery to project site/completion period.	8 Weeks after Award of Contract	
7. Tender Price(s) (Read-out)	Currency	Amount
	GH¢	818,800.00
8. Corrections	Nil	Nil
9. Discounts	Nil	Nil
10. Other Adjustments	Nil	Nil
11. Evaluated Tender Price for the Proposed Award for Procurement of Furniture for the Regional Centre for Energy and Environmental Sustainability (RCEES), UENR: Lot 2C: Lecture Hall Furniture	GH¢	818,800.00

ANNEXES

- A. TENDER OPENING RECORD FORM**
- B. TENDER OPENING MINUTES**
- C. ATTENDANCE REGISTER—TENDERERS’ REPRESENTATIVES**
- D. ATTENDANCE REGISTER—PURCHASER’S REPRESENTATIVES**
- E. REGISTER OF PURCHASE OF TENDER DOCUMENTS**
- F. COPY OF ADVERT**
- G. TENDER SUBMISSION SHEETS**

ATTACHMENTS

- A. TENDER DATA SHEET**
- B. TENDER EVALUATION SHEETS**
- C. TENDER EVALUATION MINUTES**
- D. INFORMATION SUBMITTED BY THE RECOMMENDED TENDERER**

**A. TENDER
OPENING RECORD
FORM**

**UNIVERSITY OF ENERGY AND NATURAL RESOURCES
TENDER OPENING CHECKLIST**

DATE: 20TH SEPTEMBER, 2022

PROCUREMENT METHOD: NATIONAL COMPETITIVE TENDER

CONTRACT NAME: S/NO 2: PROCUREMENT OF FURNITURE FOR THE REGIONAL CENTRE FOR ENERGY AND ENVIRONMENTAL SUSTAINABILITY (RCEES), UENR:

LOT 2A: OFFICE FURNITURE, LOT 2B: AUDITORIUM FURNITURE, LOT 2C: LECTURE HALL FURNITURE, LOT 2D: LABORATORY FURNITURE
CONTRACT PACKAGE NO.: BA/UENR/GD/006/22, BA/UENR/GD/009/22

(BA/UENR/RCEES/GD/007/22)

NO.	TENDERER'S NAME	DS	CERTIFICATES				BID SECURITY (%)	TENDER PRICE (GH¢)	REMARKS
			BRC	VAT	SSNIT	TAX			
1	WHITE PLEASURE COMPANY LIMITED	✓	✓	✓	19/10/2022	✓	23/9/2022	140k and 23,421.89	Lot 2A: 1,054,706.63 Lot 2B: 116,388.00 Lot 2C: 1,390,250.00 Lot 2D: 236,850.00
2	MAT-BANS COMPANY LIMITED	✓	✓	✓	16/10/2022	✓	14/10/2022	PHOENIX 51,620.00	Lot 2C: 818,800.00 Lot 2D: 134,900.00 Lot 2A: 1,897,672.00 Lot 2B: 428,480.00 Lot 2C: 880,238.00 Lot 2D: 120,510.00
3	CONTRA-FOCUS LIMITED	✓	✓	✓	23/9/2022	✓	22/9/2022	SIC 73,000.00	Lot 2A: 1,103,492.00 Lot 2B: 1,707,576.00 Lot 2C: 1,707,576.00 Lot 2D: 1,707,576.00
4	YEKNA INVESTMENT LIMITED	✓	✓	✓	29/9/2022	✓	4/10/2022	PHOENIX 25,000 40,000	Lot 2A: 1,103,492.00 Lot 2B: 1,707,576.00 Lot 2C: 1,707,576.00 Lot 2D: 1,707,576.00

CHAIRMAN
DATE: 20/09/2022

SECRETARY
DATE: 20/09/2022

- KEY**
- DS-Document Signed
 - VAT-Value Added Tax Certificate
 - BRC- Business Registration Certificate
 - TAX-Valid Tax Clearance Certificate
 - SSNIT-Valid SSNIT Clearance Certificate
 - PPA-Public Procurement Authority Registration Certificate

TENDER OPENING COMMITTEE MEMBERS

1. Name..... Prof. Simon Abugre
Designation..... Chairman..... Signature..... 

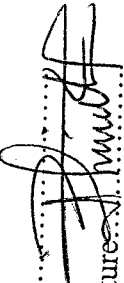
3. Name..... Paul Nana Nketiah
Designation..... Member..... Signature..... 

5. Name..... Kofi Essimoh
Designation..... Secretary..... Signature..... 

7. Name.....
Designation..... Signature.....

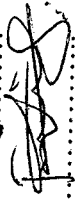
2. Name..... Francis Ampomah-Djan
Designation..... Member..... Signature..... 

4. Name..... John Baptist Siddig
Designation..... member..... Signature..... 

6. Name.....
Designation..... Signature.....

8. Name.....
Designation..... Signature.....

B. TENDER OPENING MINUTES

UNIVERSITY OF ENERGY AND NATURAL RESOURCES (UENR), SUNYANI

MINUTES OF THE TENDER OPENING PANEL MEETING FOR NATIONAL COMPETITIVE TENDERING (NCT); PROCUREMENT OF 4 x 4 SUV VEHICLE AND FURNITURE FOR THE REGIONAL CENTRE FOR ENERGY AND ENVIRONMENTAL SUSTAINABILITY (RCEES), UENR HELD ON 20TH SEPTEMBER, 2022 AT THE COUNCIL CHAMBER - UENR

MEMBERS PRESENT

1. Prof. Simon Abugre	Dean, School of Natural Resources	Chairman
2. Mr. John-Baptist Siddick	Ag. Director of Procurement	Member
3. Mr. Paul Nana Nketiah	Deputy Director of Finance	Member
4. Mr. Ebenezer T. Lanor	Transport Engineer	Member
5. Mr. Francis Amponsah-Djan	Rep. for Estate Officer	Member
6. Mr. Kofi Dwomoh	Principal Procurement Assistant	Secretary

IN- ATTENDANCE

A. TENDERERS

1. Mr. Emmanuel Adofo	Mat-Bans Company Limited
2. Mr. Emmanuel T. Cyrus	White Pleasure Company Limited
3. Mr. Eric Okyere	Contra-Focus Limited
4. Mr. Anthony Owusu	Yekna Investment Limited
5. Ms. Mildred Assibey	Yekna Investment Limited

1.0 OPENING

The meeting started with a prayer by Mr. Ebenezer T. Lanor after close of tender submission at 11: 00 am. The Chairman welcomed the Tender Opening Committee Members and tenderers representatives who were present at the tender opening and briefed them on the purpose of the meeting, which were to open the following tenders;

- (i) S/No. 1: Procurement of 4 x 4 SUV Vehicle for the Regional Centre for Energy and Environmental Sustainability (RCEES), UENR.
- (ii) S/No. 2: Procurement of Furniture for the Regional Centre for Energy and Environmental Sustainability (RCEES), UENR:
 - Lot 2A: Office Furniture,
 - Lot 2B: Auditorium Furniture,
 - Lot 2C: Lecture Hall Furniture,
 - Lot 2D: Laboratory Furniture.

UNIVERSITY OF ENERGY AND NATURAL RESOURCES (UENR), SUNYANI

The Chairman further informed the Committee and tenderers representatives that, the tender opening session was just the first stage of the tendering process and assured the tenderers of open, transparent and fair process. There was a self-introduction session by all tender Opening Panel Members and Tenderers present.

2.0 OPENING OF TENDER BOX

The locked tender box in which tenderer(s) had deposited their tender was opened in the presence of the Tender Opening Panel and tenderer's representatives who attended the tender opening.

The following Seven (7) Suppliers responded to our advert and purchased the Tender Documents;

1. Toyota Ghana Company Limited, Accra
2. Sneda Motors, Accra
3. Klataa Engineering Solutions Company Limited, Accra
4. Mat-Bans Company Limited, Accra
5. White Pleasure Company Limited, Accra
6. Contra-Focus Limited, Accra
7. Yekna Investment Limited, Accra

However, at the time for the closure of the tender submission, five (5) suppliers submitted their tender documents for the various packages. The suppliers were;

1. Klataa Engineering Solutions Company Limited, Accra
2. Mat-Bans Company Limited, Accra
3. White Pleasure Company Limited, Accra
4. Contra-Focus Limited, Accra
5. Yekna Investment Limited, Accra

3.0 SUBMISSION OF PRELIMINARY REQUIREMENTS

The preliminary requirement indicated in the tender document which the tenderers were required to submit or comply with and their tender prices were read before the tender opening panel and the representatives of tenderers who attended the tender opening meeting.

The requirements indicated in the tender document were as follows:

UNIVERSITY OF ENERGY AND NATURAL RESOURCES (UENR), SUNYANI

- Tender Signed
- Business Registration Certificate
- Valid Tax Clearance Certificate
- Valid SSNIT Clearance Certificate
- VAT Registration Certificate
- Tender Security 2% of Total Tender price
- Public Procurement Authority (PPA) Registration

The tender documents of the tenderers were examined by the committee regarding compliance with these requirements.

UNIVERSITY OF ENERGY AND NATURAL RESOURCES (UENR), SUNYANI

(i) S/No. 1: Procurement of 4 x 4 SUV Vehicle for the Regional Centre for Energy and Environmental Sustainability (RCEES), UENR.

No.	Name of Tenderer(s)	Tender Signed	Business Reg. cert	VAT certificate	Valid Tax Clearance Cert	Valid SSNIT Clearance Cert	PPA Reg. Cert	Tender Security-Bond or Bank Guarantee (2% of Tender Price)	Total Tender price (read-out)
1	Klataa Engineering Solutions Company Limited	✓	✓	✓	✓	x	✓	Bid Bond from Star Assurance GH¢40,000.00	GH¢1,740,000.00

✓: Means tenderer(s) submitted the requirement

x: Means tenderer(s) did not submit the requirement

(ii) S/No. 2: Procurement of Furniture for the Regional Centre for Energy and Environmental Sustainability (RCEES), UENR: Lot 2A: Office Furniture

No.	Name of Tenderer(s)	Tender Signed	Business Reg. cert	VAT certificate	Valid Tax Clearance Cert	Valid SSNIT Clearance Cert	PPA Reg. Cert	Tender Security-Bond or Bank Guarantee (2% of Tender Price)	Total Tender price (read-out)
1	Mat-Bans Company Limited	✓	✓	✓	✓	✓	✓	Bid Bond from Phoenix Insurance GH¢51,620.00	GH¢1,390,250.00
2	Contra-Focus Limited	✓	✓	✓	✓	✓	✓	Bid Bond from SIC Insurance GH¢73,000.00	GH¢1,897,672.00
3	Yekna Investment Limited	✓	✓	✓	✓	✓	✓	Bid Bond from Phoenix Insurance GH¢25,000.00	GH¢1,103,492.00

✓: Means tenderer(s) submitted the requirement

x: Means tenderer(s) did not submit the requirement

UNIVERSITY OF ENERGY AND NATURAL RESOURCES (UENR), SUNYANI

**(iii) S/No. 2: Procurement of Furniture for the Regional Centre for Energy and Environmental Sustainability (RCEES), UENR:
Lot 2B: Auditorium Furniture**

No.	Name of Tenderer(s)	Tender Signed	Business Reg. cert	VAT certificate	Valid Tax Clearance Cert	Valid SSNIT Clearance Cert	PPA Reg. Cert	Tender Security (2% of Tender Price)	Total Tender price (read-out)
1	Mat-Bans Company Limited	✓	✓	✓	✓	✓	✓	Bid Bond from Phoenix Insurance GH¢51,620.00	GH¢236,850.00
2	Contra-Focus Limited	✓	✓	✓	✓	✓	✓	Bid Bond from SIC Insurance GH¢73,000.00	GH¢428,480.00

✓: Means tenderer(s) submitted the requirement

x: Means tenderer(s) did not submit the requirement

**(iv) S/No. 2: Procurement of Furniture for the Regional Centre for Energy and Environmental Sustainability (RCEES), UENR:
Lot 2C: Lecture Hall Furniture**

No.	Name of Tenderer(s)	Tender Signed	Business Reg. cert	VAT Certificate	Valid Tax Clearance Cert	Valid SSNIT Clearance Cert	PPA Reg. Cert	Tender Security (2% of Tender Price)	Total Tender price (read-out)
1	White Pleasure Company Limited	✓	✓	✓	✓	✓	✓	Bid Bond from Holland Insurance GH¢23,421.89	GH¢1,054,706.63
2	Mat-Bans Company Limited	✓	✓	✓	✓	✓	✓	Bid Bond from Phoenix Insurance GH¢51,620.00	GH¢818,800.00
3	Contra-Focus Limited	✓	✓	✓	✓	✓	✓	Bid Bond from SIC Insurance GH¢73,000.00	GH¢880,238.00
4	Yekna Investment Limited	✓	✓	✓	✓	✓	✓	Bid Bond from Phoenix Insurance GH¢40,000.00	GH¢1,707,576.00

✓: Means tenderer(s) submitted the requirement

x: Means tenderer(s) did not submitted the requirement

UNIVERSITY OF ENERGY AND NATURAL RESOURCES (UENR), SUNYANI

- (iv) S/No. 2: Procurement of Furniture for the Regional Centre for Energy and Environmental Sustainability (RCEES), UENR:
 Lot 2D: Laboratory Furniture

No.	Name of Tenderer(s)	Tender Signed	Business Reg. cert	VAT Certificate	Valid Tax Clearance Cert	Valid SSNIT Clearance Cert	PPA Reg. Cert	Tender Security (2% of Tender Price)	Total Tender price (read-out)
1	White Pleasure Company Limited	✓	✓	✓	✓	✓	✓	Bid Bond from Hollard Insurance GH¢23,421.89	GH¢116,388.00
2	Mat-Bans Company Limited	✓	✓	✓	✓	✓	✓	Bid Bond from Phoenix Insurance GH¢51,620.00	GH¢134,900.00
3	Contra-Focus Limited	✓	✓	✓	✓	✓	✓	Bid Bond from SIC Insurance GH¢73,000.00	GH¢120,510.00

4.0 ADJOURNMENT

The Chairman thanked the tender opening panel and the representatives of tenderers for attending the meeting. The meeting ended with a prayer by Mr. Francis Amponsah-Djan at 2:20 p.m.

CHAIRMAN



.....

Prof. Simon Abugre

Date: 20/09/2022

SECRETARY



.....

Mr. Kofi Dwomoh

Date: 20/09/2022

**C. ATTENDANCE
REGISTER—
TENDERERS'
REPRESENTATIVES**

**D. ATTENDANCE
REGISTER—
PURCHASER'S
REPRESENTATIVES**





UNIVERSITY OF ENERGY AND NATURAL RESOURCES (UENR), SUNYANI

TENDER OPENING PANEL (TEP) MEETING (NATIONAL COMPETITIVE TENDER, NCT) FOR THE PROCUREMENT OF 4 X 4 SUV VEHICLE FOR THE REGIONAL CENTRE FOR ENERGY AND ENVIRONMENTAL SUSTAINABILITY (RCEES), UENR; PROCUREMENT OF FURNITURE FOR THE REGIONAL CENTRE FOR ENERGY AND ENVIRONMENTAL SUSTAINABILITY (RCEES), UENR; LOT 2A: OFFICE FURNITURE, LOT 2B: AUDITORIUM FURNITURE, LOT 2C: LECTURE HALL FURNITURE, LOT 2D: LABORATORY FURNITURE

ATTENDANCE LIST-STAFF

20TH SEPTEMBER, 2022

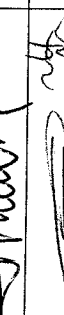
11:00 AM





NO.	NAME	DESIGNATION	SIGNATURE	TEL NO.
1	Prof. Simon Abuye	Chairman		0209500070
2	John Baptist Suddick	Member		024645558464
3	Paul Nema Nketich	Member		0240458484
4	Ebenezer T. Lexion	Member		0246954936
5	Francis Ampomah-Djan	Member		0246167445
6	Kofi Susonoh	Secretary		0208360049

**E. REGISTER OF
PURCHASE OF
TENDER
DOCUMENTS**

UNIVERSITY OF ENERGY AND NATURAL RESOURCES, SUNYANI

TENDER DOCUMENTS PURCHASE REGISTER

S/NO 2: PROCUREMENT OF FURNITURE FOR THE REGIONAL CENTRE FOR ENERGY AND ENVIRONMENTAL SUSTAINABILITY (RCEES), UENR: LOT 2C: LECTURE HALL FURNITURE

NO.	NAME OF COMPANY	NAME OF REPRESENTATIVE	DATE	TIME	TEL. NO.	RECEIPT NO.	SIGNATURE
1.	Compq-focus	Mans Osei Tutu	7/9/82	2:57	0244278105	77711	
2.	Met-Bars	Newman Anning	8/9/22	10:14	0208280717	77713	
3.	White Pleasure	Emmanuel Cyrus	8/9/22	11:02	0272074602	77714	
4.	TEKON INDUSTRIES	ALE PETER	8/9/22	4:18	024427230	07284	
5.							
6.							
7.							
8.							
9.							
10.							

**F. COPY OF
ADVERT**



'Heavy fighting' as Ukraine seeks to retake Kherson

FIERCE battles have been reported as Ukraine tries to retake the Russian-occupied southern Kherson region - but military experts have told the BBC it "won't happen quickly".

"Heavy fighting is continuing, our soldiers are working around the clock," said Vitaliy Kim, who heads the neighbouring Mykolaiv region.

Ukraine earlier said it had broken through Russia's first line of defence.

But Russia said Ukrainian troops had been defeated during a failed attack.

The defence ministry in Moscow also said there had been heavy casualties among the Ukrainian forces, but the claims by both Ukraine and Russia have not been independently verified.

Kherson became the first major Ukrainian city to fall into Russian hands in the opening days of Moscow's invasion that began on 24 February.

Top Ukrainian military officials have been tight-lipped about giving too many details about its reported counter-offensive, urging the wider public to be patient.

On Tuesday, Ukraine's Operational Command "South" reported that "positional battles" continued.

It said three key bridges across the Dnipro River had been hit again to make sure they were impassable. In recent weeks, Ukraine has also been using US-supplied HIMARS precision rocket systems to target makeshift Russian pontoon bridges, as well as command posts and ammunition depots.

This is widely seen as part of a targeted effort to cut off Russian troops on the right (western) bank of the river, making it virtually impossible to send troops and weapons resupplies.

However, officials in Kyiv have been cautioning against any expectations of a quick win, describing the offensive as a slow grinding down of the enemy.

Several military experts interviewed by the BBC seem to agree with this.

"The long-term trend is the gradual weakening of the Russian military capability and the gradual strengthening of the Ukrainian capability with Western help," said Sir Alex Younger, a former head of Britain's MI6 Secret Intelligence Service.

He said the Kherson counter-offensive was "all about the urge of Ukraine to demonstrate they can get on the front foot and in turn underpin the resolve of Ukraine and its backers into what is going to be a difficult winter". —BBC

UPPER DENKYIRA EAST MUNICIPAL ASSEMBLY INVITATION TO TENDER | PROCUREMENT OF GOODS NATIONAL COMPETITIVE TENDERING (NCT)

1. The Upper Denkyira East Municipal Assembly has been allocated funds from the District Assemblies Common Fund - Responsive Factor Grant (DAFC-RFG) and intends to apply the funds to cover eligible payments under the contract for the procurement of the under listed goods:

LOT NO.	IFT PACKAGE NO.	CONTRACT DESCRIPTION	QUANTITY (NO)	LOCATION	DELIVERY PERIOD	TENDER SECURITY
LOT 1	CR/UDE-MA/DACF-RFG/NCT/GDS/001/22	SUPPLY OF 600No. DUAL DESK FOR 15No. BASIC SCHOOLS IN THE MUNICIPALITY.	VARIOUS	DUNKWA-ON-OFFIN	3 WEEKS	2% OF THE TOTAL TENDER PRICE

1. The Upper Denkyira East Municipal Assembly now invites sealed Tenders from eligible Suppliers for the Supply of Goods listed above. Tendering will be conducted through the National Competitive Tendering (NCT) procedures specified in the Public Procurement Act, Act 663, 2003 and the Public Procurement (Amendment) Act 2016 Act 914 and the Guidelines of the Public Procurement Authority of the Republic of Ghana.

2. Interested eligible tenderers may obtain further information from the Office of the Upper Denkyira East Municipal Co-ordinating Director, and inspect the Tender documents at the address given below from 09:00 hours to 17:00 hours GMT on working days.

3. Tender documents (and additional copies) may be purchased at the address stated below for a non-refundable fee of Three Hundred Ghana Cedis (GH¢300.00) only, for each set. The document will be obtained personally and with an application letter. Tenderers are advised to use the address stated below for obtaining information, inspection and purchase of Tender Document.

4. Tenders must be deposited into the box located at the address below at or before 10:00 hours GMT on 2nd September 2022. Tenders shall be valid for a period of 90 days after the deadline of Tender submission. All Tenders must be accompanied by

a Tender Security of 2% of the total Tender price stated in the table above for each package. Late Tenders will be rejected. Tenders will be opened in the presence of the Tenderer's representative, who chooses to attend at the Conference Room of the Upper Denkyira East Municipal Assembly at 10:00 hours GMT on 16th September, 2022.

Address for information, inspection and purchase of Tender Document
Name: The Municipal Co-ordinating Director
Upper Denkyira East Municipal Assembly
Postal Address: P. O. Box DW 50,
City: Dunkwa-on-Offin
Region: Central
Country: Ghana
Telephone Number: 0332229145

Address for Tender submission and opening
Name: The Secretary,
Municipal Tender Committee
Upper Denkyira East Municipal Assembly
Postal Address: P. O. Box DW 50
City: Dunkwa-On-Offin
Region: Central
Country: Ghana
Location for Tender Submission is: Office of the Municipal Co-ordinating Director



UNIVERSITY OF ENERGY AND NATURAL RESOURCES (UENR), SUNYANI, GHANA

INVITATION FOR TENDERS NATIONAL COMPETITIVE TENDERING (NCT)

1. The University of Energy and Natural Resources, Sunyani intends to apply part of its budgetary allocation to fund eligible payments under the contracts for the supply of the underlisted items:

S/NO	Description	Quantity	Contract Package No.	Cost of Tender Document
1	Procurement of 4 x 4 SUV Vehicle for the Regional Centre for Energy and Environmental Sustainability (RCEES), UENR	1 No.	BA/UENR/GD/010/22 (BA/UENR/RCEES/GD/010/22)	GH¢ 500.00
2	Procurement of Furniture for the Regional Centre for Energy and Environmental Sustainability (RCEES), UENR: Lot 2A: Office Furniture, Lot 2B: Auditorium Furniture, Lot 2C: Lecture Hall Furniture Lot 2D: Laboratory Furniture	Various	BA/UENR/GD/006/22 BA/UENR/GD/009/22 (BA/UENR/RCEES/GD/007/22)	GH¢ 500.00 for each Lot.

2. The University of Energy and Natural Resources, Sunyani now invites sealed Tenders from eligible suppliers for the Supply of the above listed items:

Tendering will be conducted through the National Competitive Tendering (NCT) method procedures specified in the Public Procurement Act 2003 (Act 663) as amended, and the Guidelines of the Public Procurement Authority (PPA) of the Republic of Ghana.

3. Tenderers may obtain further information and inspect the tender document at the UENR Procurement Directorate Building from 9:00am to 4:00pm, each working day from Wednesday, 31st August, 2022.

4. A complete set of Tender Documents in English may be purchased by the interested Tenderers upon submission of a written application to the address below and upon payment of a non-refundable fee of GH¢ 500.00 for Tender Document for each package at the Finance Directorate, UENR.

NB: GH¢ 500.00 for the package Serial Number 1 (S/NO 1) and each Lot in Serial Number 2 (S/NO 2).

5. Tenders must be delivered to the address below at or before 11:00 a.m. on Tuesday, 20th September, 2022. Tenders shall be valid for 120 days after the deadline of submission of Tenders. All tenders must be accompanied by a Tender Security of 2% of the Tender price.

Late Tenders will not be accepted and will be returned unopened to the Tenderer. Tenders will be opened immediately after the closing time of submission of tenders in the presence of the Tenderers' representatives, who choose to attend at the University's Council Chamber, University of Energy and Natural Resources, Sunyani at 11:00 a.m., on Tuesday, 20th September, 2022.

6. Address for purpose of Tender submission:

The Vice-Chancellor
ATTN: Ag. Director of Procurement
University of Energy and Natural Resources
P.O. Box 214
Sunyani, Ghana

7. Location for the submission of tenders:

The Procurement Directorate Building
Opposite UENR Basic School
University of Energy and Natural Resources
(UENR) Sunyani, Ghana
Telephone: 0352290367/0244535464
Email: procurementdirector@uenr.edu.gh

8. It is mandatory that Tenderers include in their tender the underlisted statutory requirements.

- Valid GRA Tax Clearance Certificate.
- Valid SSNIT Clearance Certificate.
- Valid VAT Registration Certificate.
- Valid Business Registration Certificate.
- Valid Certificate of Incorporation.
- Valid Certificate of Commencement.
- Valid Registration Certificate from PPA.

REGISTRAR

**G. TENDER
SUBMISSION SHEETS**

ATTACHMENTS

A. TENDER DATA SHEET

Tender Data Sheet

The following specific data for the Goods to be procured shall complement, supplement, or amend the provisions in the Instructions to Tenderers. Whenever there is a conflict, the provisions herein shall prevail over those in Instructions to Tenderers.

Introduction	
ITT.1.1	Name of Purchaser: University of Energy and Natural Resources, Sunyani
ITT. 2.1	The Source of Funds is Internally Generated Funds (IGF)
ITT. 2.1	Name of Contract: Procurement of Furniture for the Regional Centre for Energy and Environmental Sustainability (RCEES), UENR: Lot 2A: Office Furniture, Lot 2B: Auditorium Furniture, Lot 2C: Lecture Hall Furniture Lot 2D: Laboratory Furniture
ITT 7.1	Purchaser's Name: University of Energy and Natural Resources Address: P.O Box 214, Sunyani Telephone or telex : 0352290367/0244535464 Email Address: procurementdirector@uenr.edu.gh
ITT 8.1	Purchaser can modify Tender documents before the Deadline for submission of Tenders by issuing Addenda.
ITT 9.1	Language of the Tender: English.

TENDER PRICE AND CURRENCY	
ITT 12.1 (i)	The price quoted shall be : The prices shall include all duties, taxes and other levies. The prices should be expressed in the term of EXW in Ghana Cedis (GH¢).
ITT 12.1 (ii)	The Prices for inland transportation: GH¢..... The prices for insurance: GH¢..... The prices for other local cost: GH¢.....
ITT 12.1 (iii)	The price of other incidental services : (a)GH¢..... (b)GH¢..... IGH¢..... Total CIP to [name of final destination] GH¢.....
ITT 12.4	The prices shall be fixed

ITT 13.1	The prices shall be quoted in New Ghana Cedis (GH¢)
PREPARATION AND SUBMISSION OF TENDERS	
ITT 14.3 I	<p>A. Qualification requirements.</p> <ul style="list-style-type: none"> i) The offered goods/equipment shall be latest and in current production for minimum of 2 years. If the offered model is new, the manufacturer must have experience in producing the similar model for a minimum of 2 years. ii) The Tender shall furnish a list of users who had purchased same/similar goods/equipment in last 2 years., and number of equipment sold to them. They will be used as references to check the performance of the offered model, if necessary. iii) Compliance with variation from the departmental requirement of the technical specification shall be duly filled in the offered specification column of the Technical Specification. iv) Separate Tender shall be submitted for each package. No Tender will be considered if the offered quantity is different from that specified in the Technical Specification. v) An agent can submit Tenders on behalf of more than one manufacturer but separate complete Tenders including Tender security shall be submitted for each manufacturer. vi) If an Agent submits Tenders on behalf of more than one Manufacturer, unless each such Tender is accompanied by a separate Tender Form for each Tender, and a Tender security, when required, for each Tender, and authorization from the respective Manufacturer, all such Tenders will be rejected as non-responsive. viii) Other qualifications. <p>B. ARRANGEMENT OF TENDER SUBMISSION</p> <p>Tender Should be submitted in the following order</p> <ol style="list-style-type: none"> 1. Tender Form and Price Schedule; 2. Power of Attorney; 3. Tender Security; 4. Statutory documents (SSNIT, VAT, TAX, Business Registration Certificates and PPA); 5. Technical Specification Offered; 6. Warranty, Country of Origin, Delivery Period, Payment terms, Validity Period; 7. Manufacturer's Authorization; 8. List and addresses of at least 3 users who have purchased

	<p>same/similar goods/equipment in last 2 years from your firm and the number of equipment/ goods sold to them;</p> <p>9. After Sales Service statement; and</p> <p>10. Any other information of relevance to the Tender</p>
ITT 15.3 (b)	AFTER SALES SERVICE: Tenderers should be able to Provide After Sale Services Facilities for one (1) Year after delivery of the Furniture they intend to supply (Statement of After Sale Service should be provided as evidence).
ITT 16.1	Amount of Tender Security: Two percent (2%) of total Tender Price NOTE: The Tender Security must be obtained from a reputable BANK or Recognized Insurance Companies.
ITT 17.1	Tender Validity Period: 120 days.
ITT 18.1	Number of copies: Original and three (3) copies (Making it a total of 4 Copies required for submission).
ITT 19.2 (a)	Address for Tender submission: The Vice Chancellor ATTN: Ag. Director of Procurement University of Energy and Natural Resources Sunyani.
	IFT title and number: <ul style="list-style-type: none"> • Procurement of Furniture for the Regional Centre for Energy and Environmental Sustainability (RCEES), UENR: Lot 2A: Office Furniture, Lot 2B: Auditorium Furniture, Lot 2C: Lecture Hall Furniture Lot 2D: Laboratory Furniture • BA/UENR/GD/006/22 • BA/UENR/GD/009/22 • (BA/UENR/RCEES/GD/007/22)
ITT 20.1	Deadline for Tender submission: Date : 20th September, 2022 Time : 11:00 am Place : Procurement Directorate, UENR
ITT 22.1	Deadline for Tender Modification and Withdrawal: Twenty-four (24) hours prior to the deadline for Tender Submission as per ITT 20.1 Date : 19th September, 2022 Time : 4:00 pm Place : Procurement Directorate, UENR
ITT 23.1	Tender Opening: Date : 20th September, 2022 Time : 11:00 am Place: The Council Chamber, University of Energy and Natural

TENDER EVALUATION

ITT 28.4 Criteria for Tender evaluation shall be in stages :

The evaluation will be done in stages as indicated below:

a) Stage 1: Preliminary Examination:

The tenderers qualification requirements listed below shall be treated as mandatory requirements to be used as criteria for evaluation of tenders in the first stage. Tenderers are required to provide documentary evidence for consideration.

Qualification Requirements

- Tender Signed
- Business Registration Certificate with currently renewed receipt.
- Valid Tax clearance certificate
- VAT registration certificate
- Valid SSNIT clearance certificate
- Public Procurement Authority (PPA) Registration Certificate
- Tender Security (**2% of Tender Price from Reputable Bank/ Recognized Insurance firm**)

Submission of Brochures: As apart of the requirements, tenderers are required to submit brochures on the specification of the brands they intend to supply.

Only tenderers whose tender pass the qualification requirements will be considered for the second stage.

b) Stage II. The Preliminary Examination (Commercial Responsiveness) would be done using the underlisted:

- Payment Terms (**Payments shall be done in installments but not exceeding nine months after delivery**)
- Delivery Period (**at most 8 Weeks**)
- Tender Validity Period (**at least 120 days**)
- Warranty Period (**at least one year from date of Delivery**)
- List of at least three (3) References for similar supply
- Audited financial Accounts for **2020 and 2021**

c) Stage III. The Technical Evaluation would be done using minimum specification method. Brochures submitted by tenderers will also be inspected and examined.

NB: *The submitted Brochures and/or Coloured Pictures of all the furniture intended to be supplied shall be part of the Evaluation Criteria*

Tenderers who will appropriate our specification indicated in the Technical

	<p>Specification column of the tender document will be passed to the next stage of the evaluation (Financial Evaluation)</p> <p>d). Stage IV. Evaluation of financial proposals of only the tenderers who passed the first three (3) stages will be considered for the financial evaluation.</p> <p>e) Stage V. After sales services support Capacity and willingness to provide: - Servicing & Maintenance facilities. - Availability of Spare parts.</p> <p>NB: The contract will be awarded to the tenderer who passes all the five (5) stages of evaluation.</p>
ITT 28.5 (a)	<p>Delivery schedule: Relevant parameters of delivery:</p> <p>(i) Delivery shall take place at the premises of the University. (ii) (iii) <i>[Specify relevant parameters, if any required.]</i></p> <p>Adjustment expressed as a percentage of : 0.1% per day of the value of Delayed Goods.</p>
ITT 28.5 I	<p>Cost of spare parts: GHC. [in total] : GHC. [per unit]</p> <p>Initial period of operation is: 2 years. List of items required is annexed to the Technical Specification.. Not Applicable</p>

ITT 28.5 (f)	<p>Specific additional criteria are :</p> <p>(i) (ii) (iii) <i>[If not applicable in Tender Data Sheet specify details on the evaluation method in the Technical Specifications.]</i></p>
ITT 28.5 Alternative	<p><i>[Specify the evaluation factors(s) if alternative provision is added in ITT 28.5.]</i> Not Applicable</p>
ITT 29.1	<p>A margin of preference shall be given up to 15% high cost than the lowest evaluated Tender. Not Applicable</p>
CONTRACT AWARD	
ITT 33.1	<p>Percentage for quantity increase or decrease: One Hundred per cent (100%)</p>
ITT 35.1	<p>Notification of Award shall be sent to the successful Tenderer at any time prior to expiration of Tender Validity.</p>
ITT 37.1	<p>Tenderer shall deliver a Performance Security of 10% in the amount as specified in the Notification of Award and in the form of Bank Guarantee within 14 days of the receipt of Notification of Award.</p>

**B. TENDER
EVALUATION
SHEETS**

TENDER EVALUATION FOR THE NATIONAL COMPETITIVE TENDERING: PROCUREMENT OF FURNITURE FOR THE REGIONAL CENTRE FOR ENERGY AND ENVIRONMENTAL SUSTAINABILITY (RCEES), UENR: LOT 2C: LECTURE HALL FURNITURE

S/NO 2C

BA/UENR/GD/006/22, BA/UENR/GD/009/22
(BA/UENR/RCEES/GD/007/22)

STAGE 1: PRELIMINARY REQUIREMENTS

No	Name of Tenderer(s)	Tender Signed	Business Reg. cert	VAT certificate	Valid Tax Clearance Cert	Valid SSNIT Clearance Cert	PPA Reg. Cert	Tender Security-Bond or Bank Guarantee (2% of Tender Price)	Responsive/ Non-Responsive
1	White Pleasure Company Limited	✓	✓	✓	14/10/22	19/10/22	23/09/2022	Bid Bond from Holland Insurance GH¢23,421.89	Responsive
2	Mat-Bans Company Limited	✓	✓	✓	14/10/22	16/10/22	01/09/23	Bid Bond from Phoenix Insurance GH¢51,620.00	Responsive
3	Contra-Focus Limited	✓	✓	✓	22/09/22	25/09/22	05/01/23	Bid Bond from SIC Insurance GH¢73,000.00	Responsive
4	Yekna Investment Limited	✓	✓	✓	04/10/22	29/09/22	07/11/22	Bid Bond from Phoenix Insurance GH¢40,000.00	Responsive

Signed.....
(Chairman, Tender Evaluation Panel)

Date..... 5/10/2022

Signed.....
(Secretary, Tender Evaluation Panel)

Date..... 5/10/2022

TENDER EVALUATION FOR THE NATIONAL COMPETITIVE TENDERING: PROCUREMENT OF FURNITURE FOR THE REGIONAL CENTRE FOR ENERGY AND ENVIRONMENTAL SUSTAINABILITY (RCEES), UENR:

LOT 2C: LECTURE HALL FURNITURE
S/NO 2C

BA/UENR/GD/006/22, BA/UENR/GD/009/22
 (BA/UENR/RCEES/GD/007/22)
STAGE 2: COMMERCIAL RESPONSIVENESS

	White Pleasure Company Limited	Mat-Bans Company Limited	Contra-Focus Limited	Yekna Investment Limited
REQUIREMENTS				
Payment Terms (Payments shall be done in installments but not exceeding nine months after delivery)	As Per Tender Document	As Per Tender Document	Payments shall be done in installments but not exceeding nine months after delivery	Not Provided
Delivery Period: (at most 8 Weeks)	As Per Tender Document	As Per Tender Document	8 Weeks After Award of Contract	Within 8 Weeks
Tender Validity Period: (at least 120 days)	As Per Tender Document	As Per Tender Document	180 Days	120 Days
Power of Attorney	Provided	Provided	Provided	Provided
After Sales Service: Tenderers should be able to Provide After Sale Services Facilities for one (1) Year after delivery of the Furniture they intend to supply (Statement of After Sale Service should be provided as evidence).	Provided	Provided	Provided	Provided
Warranty Period (at least one year from date of Delivery)				
Audited financial Accounts for 2020 and 2021	As Per Tender Document (2021 and 2020)	As Per Tender Document (2021 and 2020)	24 Month After Deliver	Provided
List of at least three (3) References for similar supply.	Provided	Provided	Provided (2021 and 2020)	Not Provided
Responsive/ Non-Responsive	Responsive	Responsive	Provided (2021 and 2020)	Provided
			not responsive	Not responsive

Signed.....
 (Chairman, Tender Evaluation Panel)
 Date.....

Signed.....
 (Secretary, Tender Evaluation Panel)
 Date.....

UNIVERSITY OF ENERGY AND NATURAL RESOURCES, SUNYANI

TENDER EVALUATION FOR THE NATIONAL COMPETITIVE TENDERING: PROCUREMENT OF FURNITURE FOR THE REGIONAL CENTRE FOR ENERGY AND ENVIRONMENTAL SUSTAINABILITY (RCEES), UENR: LOT 2C: LECTURE HALL FURNITURE

S/NO 2C

BA/UENR/GD/006/22, BA/UENR/GD/009/22



(BA/UENR/RCEES/GD/007/22)

STAGE 3: TECHNICAL EVALUATION

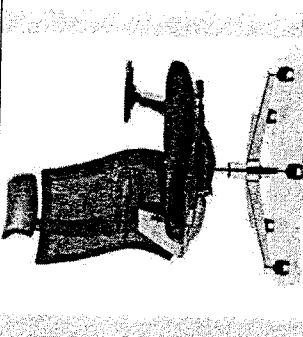
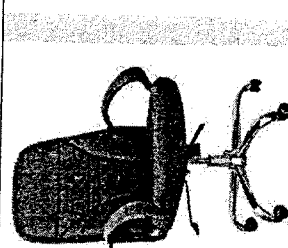
No.	MINIMUM REQUIRED SPECIFICATION	Qty	OFFERED SPECIFICATION				
			White Pleasure Company Limited	Mat-Bans Company Limited	Contra-Focus Limited	Yekna Investment Limited	
LECTURE HALL A GROUND FLOOR							
1	<p>2 In 1 Tables with Stationary Chairs: Standard Straight Desk, Legs made of aluminum, Smooth surface, Polished Wood, Durable and comfortable for lecture hall, Dimension 1.6M in length</p> 	18 No.		Complied			
2	<p>Single Table With Metal Legs: Standard Straight Desk, Legs made of aluminum, Smooth surface, Polished Wood, Durable and comfortable for lecture hall, Dimension 1.0M in length</p>	6 No.	Not Complied	Complied			
3	<p>Lecturer Table: Standard Straight Desk, Legs made of aluminum, Smooth surface, Polished Wood, Durable and comfortable for lecture hall, Dimension 1.4M in length, Movable Table</p>	4 No.		Complied			

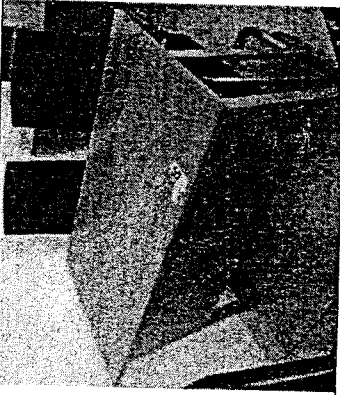
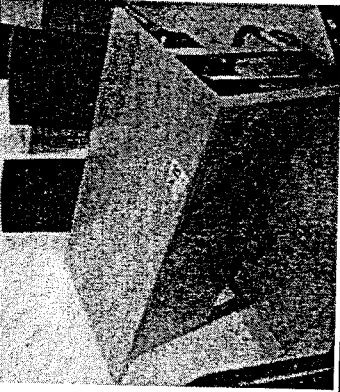
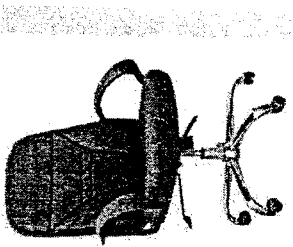
		White Pleasure Company Limited	Mat-Bans Company Limited	Contra-Focus Limited	Yekna Investment Limited
4	<p>Lecturer Swivel Chair: Black Vinyl Upholstery Seat with Passive Lumbar support Pneumatic Seat Height Adjustment, Black Nylon Loop Arms Heavy-Duty Nylon Base, Dual Wheel Carpet Casters, Dimensions: Overall: 41"-45"(H), Seat Size: 20" (W)X 19.5" (D), Seat height: 17"-21"H, Back Size: 20" (W) X 26" (H), Finish: Black /Brown, Black Nylon Loop Arms Heavy-Duty Nylon Base, Adjustable Handle with Mesh Back</p> 	4 No.	Completed		
5	<p>Swivel Chairs: Leather Swivel chair, PU upholstery front back and seat, PVC backing, Black Nylon Loop Arms Heavy-Duty Nylon Base, Dual Wheel Carpet Casters, Durable and Comfortable, Plastic Handle, Adjustable Height, Colour: Black</p> 	42 No.	Completed		
1 ST FLOOR LECTURE HALL B					
6	<p>2 In 1 Desk: Standard Straight Desk, Legs made of aluminum, Smooth surface, Polished Wood, Durable and comfortable for lecture hall, Dimension 1.6M in length</p>	17 No.	Completed		

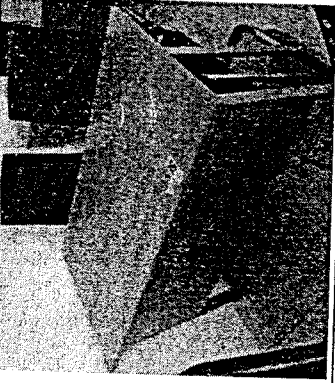

		White measure Company Limited	Mat-Bans Company Limited	Contra-Focus Limited	Yekna Investment Limited
					
7	Single Desk: Standard Straight Desk, Legs made of aluminum, Smooth surface, Polished Wood, Durable and comfortable for lecture hall, Dimension 1.0M in length	3 No.	Completed		
		Completed	Completed		
8	Swivel Chair: Leather Swivel chair, PU upholstery front back and seat, PVC backing, Black Nylon Loop Arms Heavy-Duty Nylon Base, Dual Wheel Carpet Casters, Durable and Comfortable, Plastic Handle, Adjustable Height, Colour: Black	37 No.	Completed		
		Not	Completed		

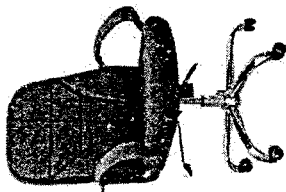
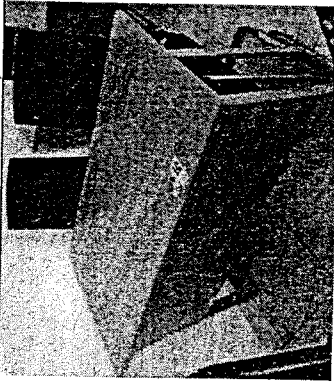
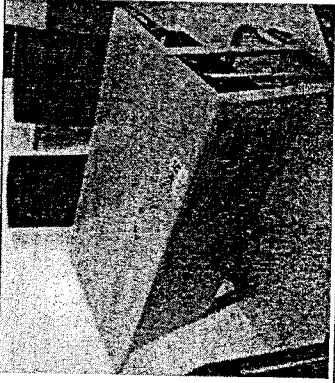
			White Pleasure Company Limited	Mat-Bans Company Limited	Contra-Focus Limited	Yekna Investment Limited
1 ST FLOOR LECTURE HALL C						
9	<p>2 In 1 Desk: Standard Straight Desk, Legs made of aluminum, Smooth surface, Polished Wood, Durable and comfortable for lecture hall, Dimension 1.6M in length</p> 	17 No.	Completed			
10	<p>Single Desk: Standard Straight Desk, Legs made of aluminum, Smooth surface, Polished Wood, Durable and comfortable for lecture hall, Dimension 1.0M in length</p> 	3 No.	Completed			
11	<p>Swivel Chair: Leather Swivel chair, PU upholstery front back and seat, PVC backing, Black Nylon Loop Arms Heavy-Duty Nylon Base, Dual Wheel Carpet Casters, Durable and Comfortable, Plastic Handle, Adjustable Height, Colour: Black</p>	37 No.	Not Completed	Completed		

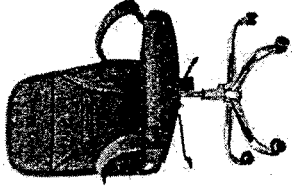
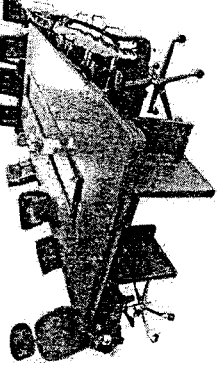

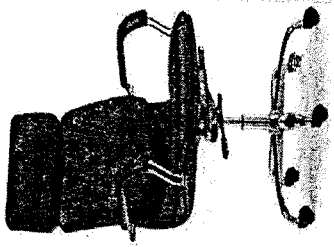
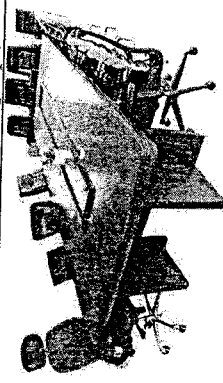
		White Measure Company Limited	Mat-Bans Company Limited	Contra-Focus Limited	Yekna Investment Limited
			Complied		
1ST FLOOR LECTURE HALL - D					
12	2 In 1 Desk: Standard Straight Desk, Legs made of aluminum, Smooth surface, Polished Wood, Durable and comfortable for lecture hall, Dimension 1.6M in length 	18 No.	Complied		
		Complied			
13	Single Desk: Standard Straight Desk, Legs made of aluminum, Smooth surface, Polished Wood, Durable and comfortable for lecture hall, Dimension 1.0M in length 	6 No.	Complied		
		NOT Complied	Complied		

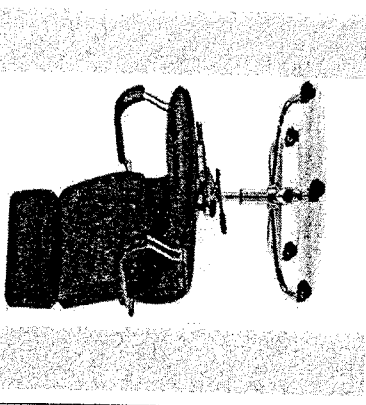
		White Measure Company Limited	Mat-Bans Company Limited	Contra-Focus Limited	Yekna Investment Limited
14	<p>Swivel Chair: Leather Swivel chair, PU upholstery front back and seat, PVC backing, Black Nylon Loop Arms Heavy-Duty Nylon Base, Dual Wheel Carpet Casters, Durable and Comfortable, Plastic Handle, Adjustable Height, Colour: Black</p> 	42 No.	Complied		
SEMINAR ROOM A- GROUND FLOOR					
15	<p>14 Seater Conference Table with Chairs: Executive design, 6 Meters dimensions, Rectangular in shape, Coffee in colour, Durable Wooden Table, Special Feature Suitable for Office, Computer, Laptop, General use</p> 	1 No.	Complied		
16	<p>Swivel Chairs: Leather Swivel chair, PU upholstery front back and seat, PVC backing, Chromed sleight frame, Head Rest Support, Adjustable Height, Durable and Comfortable for long hour of meeting, Padded leather Handle, Seat height: 17"-21"H, Back Size: 20" (W) X 26" (H), Colour: Black</p>	14 No.	Complied		

		White measure Company Limited	Mat-Bans Company Limited	Contra-Focus Limited	Yekna Investment Limited
			Completed		
		Not completed	Completed		
	SEMINAR ROOM B- GROUND FLOOR				
17	14 Seater Conference Table With Chairs: Executive design, 6 Meters dimensions, Rectangular in shape, Coffee in colour, Durable Wooden Table, Special Feature Suitable for Office, Computer, Laptop , General use				
18	Swivel Chairs: Leather Swivel chair, PU upholstery front back and seat, PVC backing, Chromed sleight frame, Head Rest Support, Adjustable Height, Durable and Comfortable for long hour of meeting, Padded leather Handle, Seat height: 17"-21"H, Back Size: 20" (W) X 26" (H), Colour: Black		Completed		

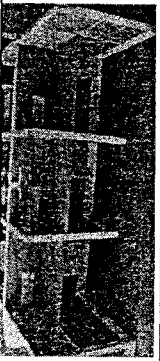
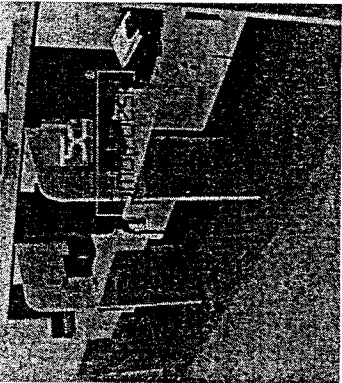
		White Pleasure Company Limited	Mat-Bans Company Limited	Contra-Focus Limited	Yekna Investment Limited
			Complied		
PHD STUDY ROOM					
19	<p>4 Seater Workstation: 4 Seater Straight workstation with Cabinets, 1.0M dimension per student, Wooden Cabinet fit to the wall for storage, Durable laminate construction is stain and scratch resistant Easy assembly (assembles in under 30 minutes), Locking pedestals can be configured left or right, Box-frame legs are constructed of 14-gauge steel, Polished Surface, Surface is 0.6M, Thickness Partition: 4.5CM, Has Electronic holes for laptop and desktop computers, printers etc</p> 	5 No.	Complied		
20	<p>5 Seater Workstation (1.0M): 4 Seater Straight workstation with Cabinets, 1.0M dimension per student, Wooden Cabinet fit to the wall for storage, Durable laminate construction is stain and scratch resistant, Easy assembly (assembles in under 30 minutes), Locking pedestals can be configured left or right, Box-frame legs are constructed of 14-gauge steel, Polished Surface, Surface is 0.6M, Thickness, Partition: 4.5CM, Has Electronic holes for laptop and desktop computers, printers etc</p>	5 No.	Not Complied		

		White Measure Company Limited	Mat-Bans Company Limited	Contra-Focus Limited	Yekna Investment Limited
					
21	<p>7 Seater Workstation (1.0M): 7 Seater Straight workstations with Cabinets, 1.0M dimension per student, Wooden Cabinets fit to the wall for storage, Durable laminate construction is stain and scratch resistant, Easy assembly (assembles in under 30 minutes), Locking pedestals can be configured left or right, Box-frame legs are constructed of 14-gauge steel, Polished Surface, Surface is 0.6M, Thickness Partition: 4.5CM, Has Electronic holes for laptop and desktop computers, printers etc</p> 	2 No.	Completed	Completed	
MASTERS STUDY HALL					
22	<p>4 Seater Workstation: 4 Seater Straight workstation with Cabinets, 1.0M dimension per student, Wooden Cabinet fit to the wall for storage, Durable laminate construction is stain and scratch resistant Easy assembly (assembles in under 30 minutes), Locking pedestals can be configured left or right, Box-frame legs are constructed of 14-gauge steel, Polished Surface, Surface is 0.6M, Thickness Partition: 4.5CM, Has Electronic holes for laptop and desktop computers, printers etc</p>	10 No.	NOT	Completed	

		White Pleasure Company Limited	Mat-Bans Company Limited	Contra-Focus Limited	Yekna Investment Limited
			<i>Comp/level</i>		
23	<p>5 Seater Workstation (1.0M): 4 Seater Straight workstation with Cabinets, 1.0M dimension per student, Wooden Cabinet fit to the wall for storage, Durable laminate construction is stain and scratch resistant, Easy assembly (assembles in under 30 minutes), Locking pedestals can be configured left or right, Box-frame legs are constructed of 14-gauge steel, Polished Surface, Surface is 0.6M, Thickness Partition: 4.5CM, Has Electronic holes for laptop and desktop computers, printers etc</p>	<i>Comp/level</i>	<i>Comp/level</i>		
			<i>Comp/level</i>		
24	<p>7 Seater Workstation (1.0M): 7 Seater Straight workstations with Cabinets, 1.0M dimension per student, Wooden Cabinets fit to the wall for storage, Durable laminate construction is stain and scratch resistant, Easy assembly (assembles in under 30 minutes), Locking pedestals can be configured left or right, Box-frame legs are constructed of 14-gauge steel, Polished Surface, Surface is 0.6M, Thickness Partition: 4.5CM, Has Electronic holes for laptop and desktop computers, printers etc</p>	<i>Comp/level</i>	<i>Comp/level</i>		

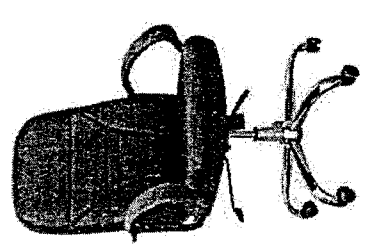
		White treasure Company Limited	Mau-Bans Company Limited	Contra-focus Limited	Yekna Investment Limited
				<i>Completed</i>	
PHD and Masters Study Hall					
25	<p>Swivel Chair: Black Vinyl Upholstery Seat with Passive Lumbar support Pneumatic Seat Height Adjustment, Black Nylon Loop Arms Heavy-Duty Nylon Base, Dual Wheel Carpet Casters, Dimensions: Overall: 41"-45"(H), Seat Size: 20" (W)X 19.5"(D), Seat height: 17"-21"H, Back Size: 20" (W) X 26" (H), Finish: Black /Brown, Black Nylon Loop Arms Heavy-Duty, Nylon Base</p> 	80 No.	<i>Completed</i>		
LIBRARY HALL					
26	<p>Metal With Wood Curve Workstation: Executive design, 14 Meters dimensions, Curve is shape, Coffee in colour, Durable Wooden Table, Partition of 1.0M per student</p>	9 No.		<i>Completed</i>	

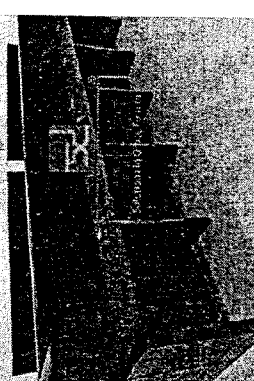
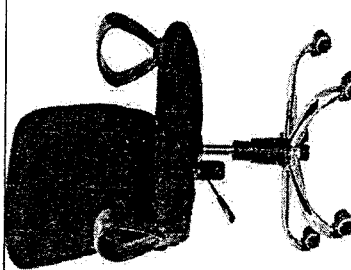
		White Pleasure Company Limited	Mat-Bans Company Limited	Contra-Focus Limited	Yekna Investment Limited
			Completed		
27	20 Seating Capacity Library Tables: Executive design, 14 Meters dimensions, Rectangular in shape, Coffee in colour, Durable Wooden Table, Partition of 1.0M per student	11 No.	Completed		
		Completed			
28	Library Swivel Chair: Office Swivel Chair, Black Vinyl Upholstery seat with Passive Lumber support Pneumatic Seat Height Adjustment, Black Nylon Loop Arms Heavy-Duty Nylon Base, Dual Wheel Carpet Casters, Arm rest	20 No.	Not		
			Completed		

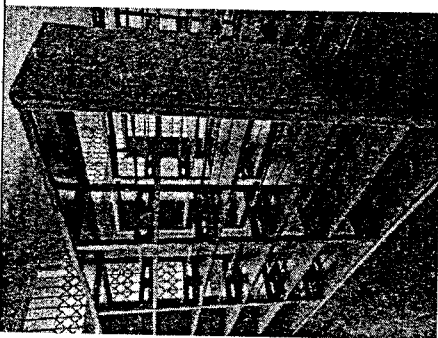
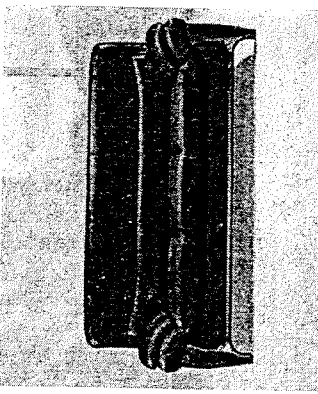
		White Pleasure Company Limited	Mat-Bans Company Limited	Contra-Focus Limited	Yekna Investment Limited
29	<p>Metal Library Bookshelves: High quality cold-rolled plate, Hardness to meet the load bearing requirement, Flexible combination, Scientific division, User -Friendly design, Anti-corrosion moisture, Easy to install and remove, simple and convenient</p> 	5 No.	Complied		
30	<p>3 In 1 Sofa</p> 	1 No.	Complied		
31	<p>Executive Swivel Chair: Executive Mesh Swivel Chair, Black Vinyl Upholstery seat with Passive Lumber support Pneumatic Seat Height Adjustment, Black Nylon Loop Arms Heavy-Duty Nylon Base, Dual Wheel Carpet Casters, Arm rest and head rest, Adjustable handle, Dimension: 22.5" x 22" 33H</p>	1 No.	Complied		

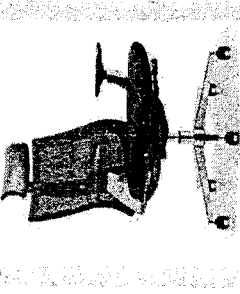
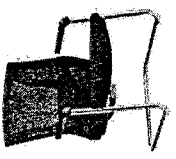
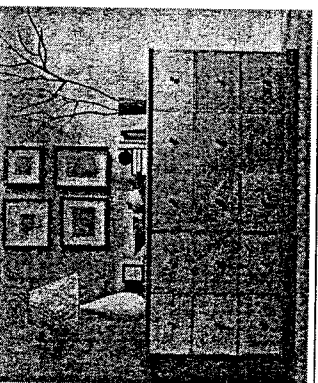
		Whitbread Company Limited	Martins Company Limited	Ultra-Focus Limited	Yeha Investment Limited
			Completed	Completed	
32	Visitor Chair: Fully upholstered in high grade black Mesh, Chrome base and chrome arms (metal arms), Seat Height: (min-max) 450mm-530mm, Back width X Height: Medium Back 520 x 580mm, Back Width x Height High back: 520mm x 700mm, Seat Width x Depth: 520mm x 520mm. Seat Width x Depth: including arms: 630mm	4 No.	Completed	Completed	
			Completed	Completed	
33	24 Pigeon Holes Cabinet: Metal shelves into cube size, Partition into 24 holes, Key lock for every hole, Each hole is 17 x 17 inches, Durable and Executive in nature, Suitable for a Library	1 Set	Completed	Completed	
			Completed	Completed	
34	Executive 1.6M Desk: Executive L-Shaped Office Desk With Chest of Drawers, L-Shaped and drawers are movable, Padded writing space, Material Make: Made of Hard Chip, First Grade, Polished wood with smooth surface, Durable, Colour: Cherry or Coffee, Size: 1.6M	1 No.	Completed	Completed	

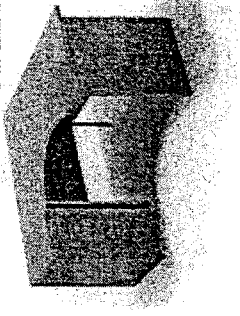
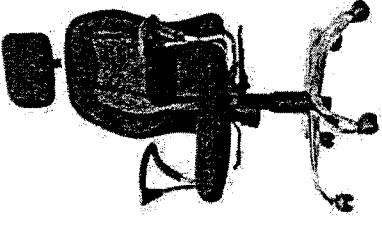
		Whitbread Company Limited	Maat-Dans Company Limited	Contra-Focus Limited	Yekna Investment Limited
		Complied	Complied	Complied	
35	Swivel Chair: Office Mesh Swivel Chair, Black Vinyl Upholstery seat with Passive Lumber support Pneumatic Seat Height Adjustment, Black Nylon Loop Arms Heavy-Duty Nylon Base, Dual Wheel Carpet Casters, Arm and Head rest, Dimension: 22.5" x 22" 33H	Complied	Complied	Complied	
		Not	Complied		
	Responsive/ Non-Responsive	NOT RESPONSIVE	RESPON SUC		

Signed.....
(Chairman, Tender Evaluation Panel)

Date.....

Signed.....
(Secretary, Tender Evaluation Panel)

Date.....

UNIVERSITY OF ENERGY AND NATURAL RESOURCES, SUNYANI

TENDER EVALUATION FOR THE NATIONAL COMPETITIVE TENDERING: PROCUREMENT OF FURNITURE FOR THE REGIONAL CENTRE FOR ENERGY AND ENVIRONMENTAL SUSTAINABILITY (RCEES), UENR: LOT 2C: LECTURE HALL FURNITURE

S/NO 2C

BA/UENR/GD/006/22, BA/UENR/GD/009/22

(BA/UENR/RCEES/GD/007/22)

STAGE 4: FINANCIAL EVALUATION

Name of Tenderers	Price Readout (GH¢)	Corrected Tender Price (GH¢)	Converted to Common Currency (GH¢)	Ranking	Recommended Tenderer	Justifications
White Pleasure Company Limited	1,054,706.63	1,054,706.63				
Mat-Bans Company Limited	818,800.00	818,800.00		1st	MAT-BANS COMPANY LIMITED	LOWER EVALUATED TENDER
Contra-Focus Limited	880,238.00	880,238.00				
Yekna Investment Limited	1,707,576.00	1,707,576.00				

Signed.....
(Chairman, Tender Evaluation Panel)

Date.....

Signed.....
(Secretary, Tender Evaluation Panel)

Date.....

UNIVERSITY OF ENERGY AND NATURAL RESOURCES, SUNYANI
TENDER EVALUATION FOR THE NATIONAL COMPETITIVE TENDERING: PROCUREMENT OF FURNITURE
FOR THE REGIONAL CENTRE FOR ENERGY AND ENVIRONMENTAL SUSTAINABILITY (RCEES), UENR:
LOT 2C: LECTURE HALL FURNITURE

S/NO 2C

BA/UENR/GD/006/22, BA/UENR/GD/009/22
 (BA/UENR/RCEES/GD/007/22)

STAGE 5: AFTER SALES SERVICE REQUIREMENT

Name of Tenderer(s)	Provision of After Sales Service Statement
MAT - MATS COMPANY LIMITED	provided

Signed.....
 (Chairman, Tender Evaluation Panel)
 Date..... 5 Jul 2022

Signed.....
 (Secretary, Tender Evaluation Panel)
 Date..... 05/10/2022

TENDER EVALUATION COMMITTEE MEMBERS

1. Name... Prof. Simon Abugre
Designation... Chairman
Signature... 

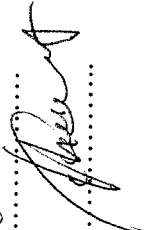
3. Name... John-Beyfest Seddich
Designation... Member
Signature... 

5. Name... Kofi Basomah
Designation... Secretary
Signature... 

7. Name.....
Designation..... Signature.....

2. Name... Paul Nana Nketey
Designation... Member
Signature... 

4. Name... Kwadky Obeng Mireku
Designation... Member
Signature... 

6. Name.....
Designation..... Signature.....

8. Name.....
Designation..... Signature.....

**C. TENDER
EVALUATION
MINUTES**

MINUTES OF TENDER EVALUATION PANEL (TEP) MEETING HELD ON WEDNESDAY, 5TH OCTOBER, 2022 AT THE GETFUND HOSTEL'S CONFERENCE ROOM, UENR

A. PRESENT

1. Prof. Simon Abugre	Dean, School of Natural Resources	Chairman
2. Mr. John-Baptist Siddick	Ag. Director of Procurement	Member
3. Mr. Paul Nana Nketiah	Deputy Director of Finance	Member
4. Mr. Ebenezer T. Lanor	Transport Engineer	Member
5. Mr. Kwaku O. Mireku	Estate Officer	Member
6. Mr. Kofi Dwomoh	Principal Procurement Assistant	Secretary

1.0 OPENING

The meeting started at 10.30 p.m. with a prayer by the Chairman, Prof. Simon Abugre. The Chairman then welcomed the Panel Members and briefed them on the purpose of the meeting, which was to evaluate the following tenders;

S/No. 1: Procurement of 4 x 4 SUV Vehicle for the Regional Centre for Energy and Environmental Sustainability (RCEES), UENR

S/No. 2: Procurement of Furniture for the Regional Centre for Energy and Environmental Sustainability (RCEES), UENR:

Lot 2A: Office Furniture,

Lot 2B: Auditorium Furniture,

Lot 2C: Lecture Hall Furniture,

Lot 2D: Laboratory Furniture.

At this stage, the Chairman asked the Team from Procurement Directorate to take members through the Evaluation Process.

2.0 MAIN BUSINESS: NATIONAL COMPETITIVE TENDERS

- (i) *S/No. 1: Procurement of 4 x 4 SUV Vehicle for the Regional Centre for Energy and Environmental Sustainability (RCEES), UENR*

One (1) firm, namely: **Klataa Engineering Solutions Limited** submitted tender.

The Submissions were as follows;

- (i) Klataa Engineering Solutions Limited - GH¢ 1,740,000.00

The firm was however disqualified because they submitted an Official Receipt instead of Clearance Certificate from SSNIT as requested.

Recommendations:

There was no Recommendation for Award of Contract.

(ii) *S/No. 2: Procurement of Furniture for the Regional Centre for Energy and Environmental Sustainability (RCEES), UENR: Lot 2A: Office Furniture*

Three (3) firms, namely: **Mat-Bans Company Limited; Contra-Focus Limited; and Yekna Investment Limited** submitted tenders.

The Submissions were as follows;

- (i) Mat-Bans Company Limited- GH¢1,390,250.00
- (ii) Contra-Focus Limited - GH¢1,897,672.00
- (iii) Yekna Investment Limited - GH¢1,103,492.00

The underlisted firms were not substantially responsive based on the following reasons:

- a. **Contra-Focus Limited** was not responsive because the List of references provided by the firm were not related to Office Furniture.
- b. **Yekna Investment Limited** was not responsive because of the following reasons;
 - The firm did not provide information on payment terms as requested.
 - The firm did not provide Audited Financial Accounts for 2020 and 2021 as requested

Recommendations:

On the basis of the evaluation which was carried out in accordance with the Tender Documents, the Panel recommended the acceptance of **Mat-Bans Company Limited** at a total Tender Price of **GH¢1,390,250.00**

(iii) *Procurement of Furniture for the Regional Centre for Energy and Environmental Sustainability (RCEES), UENR: Lot 2B: Auditorium Furniture,*

Two (2) firms, namely: **Mat-Bans Company Limited; and Contra-Focus Limited** submitted tenders.

The Submissions were as follows;

- (i) Mat-Bans Company Limited- GH¢236,850.00
- (ii) Contra-Focus Limited - GH¢428,480.00

Contra-Focus Limited was not substantially responsive because List of references provided by the firm were not related to Auditorium Furniture.

Recommendations:

On the basis of the evaluation which was carried out in accordance with the Tender Documents, the Panel recommended acceptance of **Mat-Bans Company Limited** at a total Tender Price of **GH¢236,850.00**.

(iv) *Procurement of Furniture for the Regional Centre for Energy and Environmental Sustainability (RCEES), UENR: Lot 2C: Lecture Hall Furniture.*

Four (4) firms, namely: **White Pleasure Company Limited; Mat-Bans Company Limited; Contra-Focus Limited; and Yekna Investment Limited** submitted tenders

The Submission was as follows;

- (i) White Pleasure Company Limited - GH¢1,054,706.63

- (ii) Mat-Bans Company Limited- GH¢818,800.00
- (iii) Contra-Focus Limited - GH¢880,238.00
- (iv) Yekna Investment Limited - 1,707,576.00

The underlisted firms were not substantially responsive based on the following reasons:

- a. **White Pleasure Company Limited** was not responsive because the firm's proposed Lecture Hall Furniture did not meet our Technical Requirement.
- b. **Contra-Focus Limited** was not responsive because the List of References they provided were not related to Lecture Hall Furniture.
- c. **Yekna Investment Limited** was not responsive because of the following reasons;
 - They did not provide information on the Payment Terms requirement as requested.
 - They did not provide Audited Financial Accounts for 2020 and 2021 as requested

Recommendations:

On the basis of the evaluation which was carried out in accordance with the Tender Documents, the Panel recommended acceptance of **Mat-Bans Company Limited** at a total Tender Price of **GH¢818,800.00**.

- (v) *Procurement of Furniture for the Regional Centre for Energy and Environmental Sustainability (RCEES), UENR: Lot 2C: Lecture Hall Furniture.*

Three (3) firms, namely: **White Pleasure Company Limited; Mat-Bans Company Limited; and Contra-Focus Limited** submitted tenders

The Submission was as follows;

- (i) White Pleasure Company Limited - GH¢116,388.00
- (ii) Mat-Bans Company Limited- GH¢134,900.00
- (iii) Contra-Focus Limited - GH¢120,510.00

Contra-Focus Limited was not substantially responsive because the List of References that the firm provided were not related to Office Furniture

Recommendations:

On the basis of the evaluation which was carried out in accordance with the Tender Documents, the Panel recommended acceptance of **White Pleasure Company Limited** at a total Tender Price of **GH¢116,388.00**.

3.0 ADJOURNMENT

The Chairman expressed appreciation to the Panel for their time, participation, and contribution to the Evaluation Process. The meeting ended at 2.50 p.m.



.....
Prof. Simon Abugre

Date: 05/10/2022



.....
Mr. Kofi Dwomoh

Date: 05/10/2022

**D. INFORMATION
SUBMITTED BY THE
RECOMMENDED
TENDERER**

COPY

REPUBLIC OF GHANA

UNIVERSITY OF ENERGY AND
NATURAL RESOURCES, SUNYANI

PROCUREMENT OF FURNITURE FOR THE
REGIONAL CENTRE FOR ENERGY AND
ENVIRONMENTAL SUSTAINABILITY
(RCEES), UENR:

S/NO 2

IFT NO.: LOT 2A: OFFICE FURNITURE

LOT 2B: AUDITORIUM FURNITURE

LOT 2C: LECTURE HALL FURNITURE

LOT 2D: LABORATORY FURNITURE

NATIONAL COMPETITIVE TENDERING (NCT)

MAT-BANS COMPANY LTD.

P. O. BOX AN 5285

ACCRA - NORTH

MOB: 0243-201535

AUGUST, 2022

LOT 2A, 2B, 2C, 2D

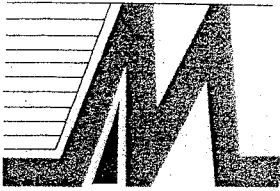

MAT-BANS COMPANY LTD.

Dealers in both Home & Office Furniture, Office Supplies and General Merchant

Our Ref..... Your Ref..... Date.....

20th September, 2022

The Vice-Chancellor
ATTN: Ag. Director of Procurement
University of Energy and Natural Resources
P. O. Box 214
Sunyani, Ghana

Dear Sir/Madam,

PROCUREMENT OF FURNITURE

IFT NO: BA/UENR/GD/006/22

BA/UENR/GD/009/22

(BA/UENR/RCEES/GD/007/22)

DECLARATION OF BIDDER'S ELIGIBILITY

The Bidder, MAT-BANS COMPANY LIMITED hereby declares that:

MAT-BANS COMPANY LIMITED is a registered company in Ghana.

MATBANS COMPANY LIMITED has been duly authorized by the manufacturers to supply the Furniture to Ghana.

Yours faithfully,
for: MAT-BANS COMPANY LTD

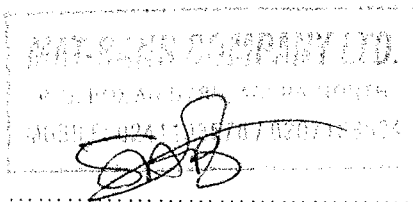

Godfred Nkansah
(Managing Director)

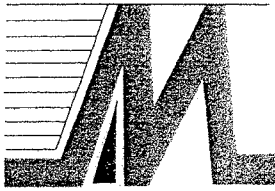

MAT-BANS COMPANY LTD.

Dealers in both Home & Office Furniture, Office Supplies and General Merchant

Our Ref..... Your Ref..... Date.....

20th September, 2022

The Vice-Chancellor
ATTN: Ag. Director of Procurement
University of Energy and Natural Resources
P. O. Box 214
Sunyani, Ghana

Dear Sir/Madam,

PROCUREMENT OF FURNITURE

IFT NO: BA/UENR/GD/006/22

BA/UENR/GD/009/22

(BA/UENR/RCEES/GD/007/22)

DECLARATION OF ELIGIBILITY OF GOODS

The FURNITURE to be supplied is in conformity with the instruction to Bidders.

All the FURNITURE is manufactured and originates from CHINA.

Yours faithfully,
for: MAT-BANS COMPANY LTD

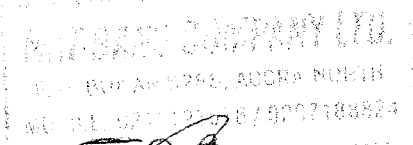

.....
Godfred Nkansah
(Managing Director)

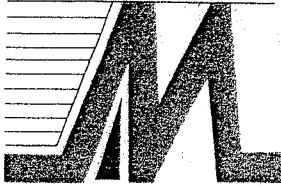

MAT-BANS COMPANY LTD.

Dealers in both Home & Office Furniture, Office Supplies and General Merchant

Our Ref.....Your Ref.....Date.....

20th September, 2022

The Vice-Chancellor
ATTN: Ag. Director of Procurement
University of Energy and Natural Resources
P. O. Box 214
Sunyani, Ghana

Dear Sir/Madam,

PROCUREMENT OF FURNITURE

IFT NO: BA/UENR/GD/006/22

BA/UENR/GD/009/22

(BA/UENR/RCEES/GD/007/22)

SERVICES PROVIDED BY MAT-BANS COMPANY LIMITED

SERVICE AND SUPPORT;

Mat-Bans Company Limited is committed to after sales service and strives hard to satisfy our clients' needs. Our goal is to develop a relationship with your institution and be proactive in information technology solutions rather than be reactive.

INSTALLATION:

Mat-Bans Company Limited will assembly all the Furniture and make sure they are in good conditions before delivery to your premises for no fee. If assembly is to be done outside Accra, we will request transportation and board expenses incurred by our technicians to be settled.

TRAINING:

Basic training is provided for Staff or Personnel by our competent technicians on the use of the Furniture on instructions.

Yours faithfully,
for: MAT-BANS COMPANY LTD

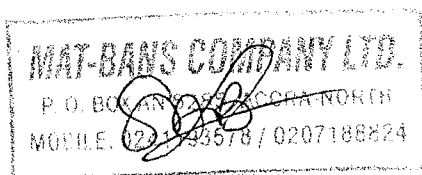

Godfred Nkansah
(Managing Director)

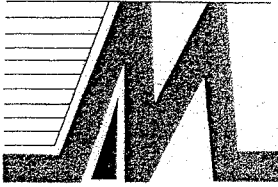

MAT-BANS COMPANY LTD.

Dealers in both Home & Office Furniture, Office Supplies and General Merchant

Our Ref..... Your Ref..... Date.....

20th September, 2022

The Vice-Chancellor
ATTN: Ag. Director of Procurement
University of Energy and Natural Resources
P. O. Box 214
Sunyani, Ghana

Dear Sir/Madam,

PROCUREMENT OF FURNITURE

IFT NO: BA/UENR/GD/006/22

BA/UENR/GD/009/22

(BA/UENR/RCEES/GD/007/22)

PROPOSAL ON LOCAL AFTER SALES

Showroom

MAT-BANS COMPANY LIMITED operates a base workshop at Kokomlemle and has its main showroom at Kokomlemle, Accra opposite JOY FM.

Our goods are consistently maintained in good condition and operate a sales showroom, at Kokomlemle and Ofankor

The division is primarily responsible for the following after-sales services

Ensuring ready availability of service

Ensuring an effective and efficient service operation standards

Ensuring an orderly, consistent customer follow-up schedule with our customers, and

Improving the level of our service management.

Yours faithfully,

for: MAT-BANS COMPANY LIMITED

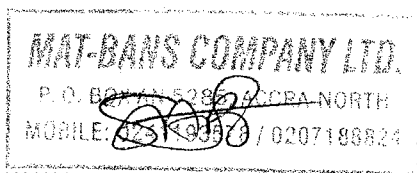

Godfred Nkansah
(Managing Director)

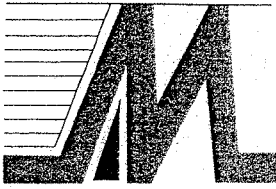

MAT-BANS COMPANY LTD.

Dealers in both Home & Office Furniture, Office Supplies and General Merchant

Our Ref.....Your Ref.....Date.....

20th September, 2022

The Vice-Chancellor
ATTN: Ag. Director of Procurement
University of Energy and Natural Resources
P. O. Box 214
Sunyani, Ghana

Dear Sir/Madam,

PROCUREMENT OF FURNITURE

IFT NO: BA/UENR/GD/006/22

BA/UENR/GD/009/22

(BA/UENR/RCEES/GD/007/22)

Service Personnel

The company has Twelve (12) full time and Six (6) part-time fully-qualified technicians who are skilled in assembling and/or repairs/maintenance of various chairs. The 6, after Sales Personnel have all graduated with an HND in Mechanical and Electrical Engineering from the Country's Polytechnic. They have been assembling, various types of chairs, and installation of other electronic machines etc and have worked with the company for several years. They have attended a lot of in-service training to improve their technical skills.

The company has some technicians on call in cases of emergency. They have all received the necessary technical education and gained practical-hands on experience in the areas mentioned above.

Warehouses – Asofan and Ofankor

MAT-BANS COMPANY LIMITED has warehouses situated at Ofankor, Accra, opposite phobia spot and also another one at Asofan, Accra opposite the Goil Filling Station which is stocked throughout the year.

Yours faithfully,

for: MAT-BANS COMPANY LTD

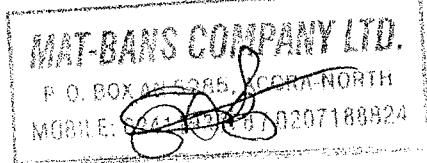

Godfred Nkansah
(Managing Director)

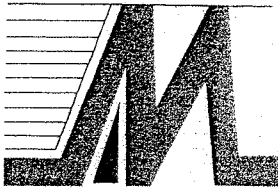

MAT-BANS COMPANY LTD.

Dealers in both Home & Office Furniture, Office Supplies and General Merchant

Our Ref. Your Ref. Date

20th September, 2022

The Vice-Chancellor
ATTN: Ag. Director of Procurement
University of Energy and Natural Resources
P. O. Box 214
Sunyani, Ghana

Dear Sir/Madam,

PFROUREMENT OF FURNITURE

IFT NO: BA/UENR/GD/006/22

BA/UENR/GD/009/22

(BA/UENR/RCEES/GD/007/22)

TERMS AND CONDITIONS OF OUR BID

Payment:

As per Tender Document.

Delivery:

As per Tender Document

Validity:

As per Tender Document

Warranty:

As per Tender Document

Yours faithfully,
for: MAT-BANS COMPANY LTD

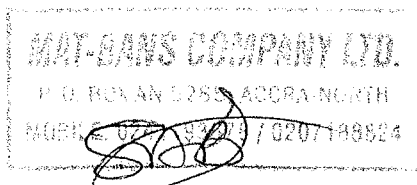

Godfred Nkansah
(Managing Director)

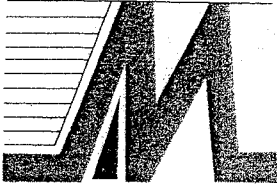

MAT-BANS COMPANY LTD.

Dealers in both Home & Office Furniture, Office Supplies and General Merchant

Our Ref.....Your Ref.....Date.....

20th September, 2022

The Vice-Chancellor
ATTN: Ag. Director of Procurement
University of Energy and Natural Resources
P. O. Box 214
Sunyani, Ghana

Dear Sir/Madam,

PROCUREMENT OF FURNITURE

IFT NO: BA/UENR/GD/006/22

BA/UENR/GD/009/22

(BA/UENR/RCEES/GD/007/22)

WARRANTY CERTIFICATE

We warrant The Various Furniture against defects in material and workmanship under normal use for a period of **12 Months** from the date of delivery.

This warranty may be enforced by the end user purchaser. This warranty is non-transferable.

The warranty includes **12 Months** coverage for all defects in material and workmanship of the Furniture.

WHAT IS NOT COVERED

1. Damage, deterioration or malfunction resulting from, but not limited to;
 - a. Accident (such as spilled liquids or dropping), misuse, abuse, neglect, fire, water lightning or other acts of nature, unauthorized product modification, or usage not in accordance with the product instructions.
2. Use of parts and components not supplied by the manufacturer.

Yours faithfully,
for: **MAT-BANS COMPANY LTD**

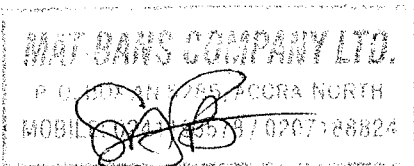

.....
Godfred Nkansah
(Managing Director)

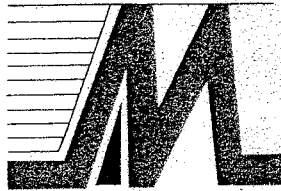

MAT-BANS COMPANY LTD.

Dealers in both Home & Office Furniture, Office Supplies and General Merchant

Our Ref.....Your Ref.....Date.....

The Vice-Chancellor
ATTN: Ag. Director of Procurement
University of Energy and Natural Resources
P. O. Box 214
Sunyani, Ghana

TENDER FORM AND PRICE SCHEDULES

Date: 20th September, 2022
IFT No.: BA/UENR/GD/006/22
BA/UENR/GD/009/22
(BA/UENR/RCEES/GD/007/22)

UNIVERSITY OF ENERGY AND NATURAL RESOURCES, SUNYANI

Gentlemen and/or Ladies:

Having examined the Tender documents including Addenda Nos, the receipt of which is hereby duly acknowledged, we, the undersigned, offer to supply and deliver **PROCUREMENT OF FURNITURE** in conformity with the said Tender documents for the sum of **Two Million, Five Hundred and Eighty Thousand, Eighty Hundred Ghana Cedis (Gh¢ 2,580,800.00)** LOT 2A(Gh¢ 1,390,250.00) LOT 2B(Gh¢ 236,850.00) LOT 2C(Gh¢ 818,800.00) LOT 2D(Gh¢ 134,900.00) or such other sums as may be ascertained in accordance with the Schedule of Prices attached herewith and made part of this tender.

We undertake, if our Tender is accepted, to deliver the goods and services in accordance with the delivery schedule specified in the Schedule of Requirements.

If our Tender is accepted, we will provide a Bank Guarantee acceptable to the Purchaser in a sum equivalent to 15% percent of the Contract Price for the due performance of the Contract, in the form prescribed by the Purchaser.

We agree to abide by this Tender for a period of **120 days** from the date fixed for Deadline for Tender submission, and it shall remain binding upon us and may be accepted at any time before the expiration of that period.
"None"

Until a formal Contract is prepared and executed, this Tender, together with your written acceptance thereof and your notification of award, shall constitute a binding Contract between us.

We understand that you are not bound to accept the lowest or any tender you may receive.

We certify/confirm that we comply with the eligibility requirements as per ITT Clause 2 of the Tender documents.

Dated this 20 day of September, 2022

Name: Godfred Nkansah in the Capacity of Managing Director,

Signed:.....

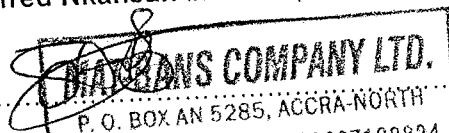



Duly authorized to sign Tender for and on behalf of: MAT-BANS COMPANY LIMITED.

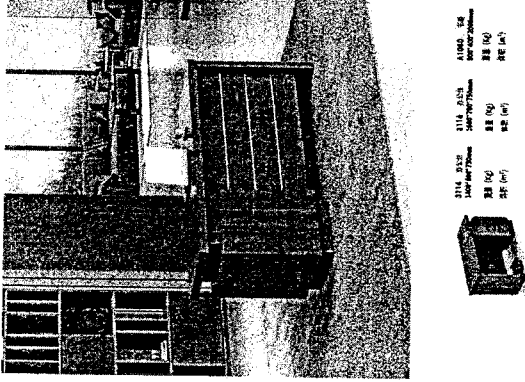

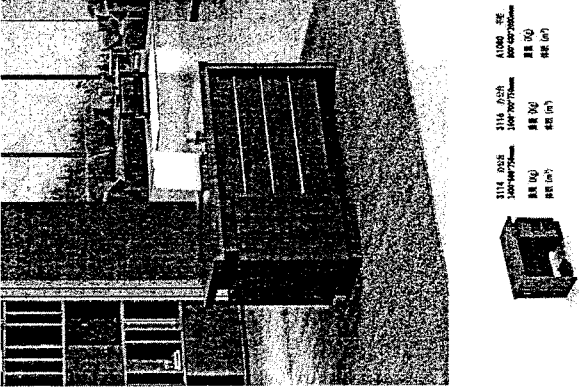
**UNIVERSITY OF ENERGY AND NATURAL RESOURCES-SUNYANI
 TECHNICAL SPECIFICATIONS/PRICE SCHEDULE FOR WORLD BANK PROJECT
 S/NO. 2: PROCUREMENT OF FURNITURE FOR THE REGIONAL CENTRE FOR ENERGY AND ENVIRONMENTAL SUSTAINABILITY
 (RCEES). UENR LOT 2A: OFFICE FURNITURE**

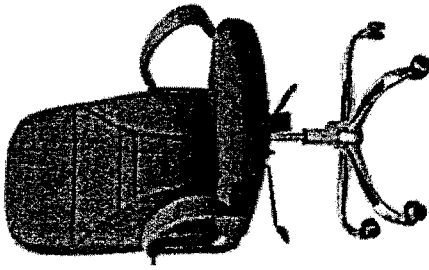
1	EXECUTIVE 1.4M (3114) (Sound Room and Security Room)	<input type="checkbox"/> Material Make: Made of Hard Chip or Hard Fibre <input type="checkbox"/> First Grade <input type="checkbox"/> Polished Surface Finished <input type="checkbox"/> Size: 1.4M <input type="checkbox"/> Colour: Coffee Dark <input type="checkbox"/> Executive L-Shaped Office Desk With Chest of Drawers <input type="checkbox"/> L-Shaped and drawers are movable <input type="checkbox"/> Padded writing space <input type="checkbox"/> Material Make: Made of Hard Chip <input type="checkbox"/> First Grade <input type="checkbox"/> Polished wood with smooth surface <input type="checkbox"/> Durable <input type="checkbox"/> Size: 1.6M	 <p> 3114 3114 1000x1600mm 3114 3114 1000x1600mm 3114 3114 1000x1600mm 3114 3114 1000x1600mm 3114 3114 1000x1600mm 3114 3114 1000x1600mm </p>	3	2,800.00	8,400.00
---	---	---	---	---	----------	----------

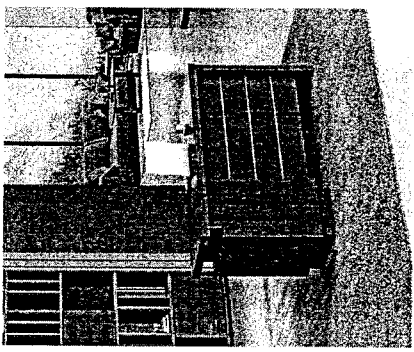
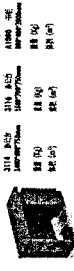

2	Executive 1.6M Desk (3116) (Reception)	<input type="checkbox"/> Material Make: Made of Hard Chip or Hard Fibre <input type="checkbox"/> First Grade <input type="checkbox"/> Polished Surface Finished <input type="checkbox"/> Size: 1.4M <input type="checkbox"/> Colour: Coffee Dark <input type="checkbox"/> Executive L-Shaped Office Desk With Chest of Drawers <input type="checkbox"/> L-Shaped and drawers are movable <input type="checkbox"/> Padded writing space <input type="checkbox"/> Material Make: Made of Hard Chip <input type="checkbox"/> First Grade <input type="checkbox"/> Polished wood with smooth surface <input type="checkbox"/> Durable <input type="checkbox"/> Size: 1.6M		1	3,700.00	3,700.00
---	--	---	--	---	----------	----------

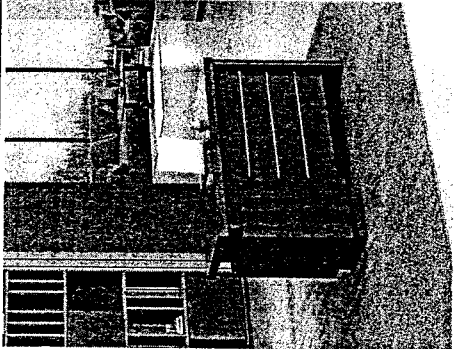
3	<p>Executive Swivel Chair –MB 36 (Reception, Security, and Sound area) (Move 3 chairs to the Waiting area)</p>	<ul style="list-style-type: none"> <input type="checkbox"/> Black Vinyl Upholstery Seat with Passive Lumbar support Pneumatic Seat Height Adjustment <input type="checkbox"/> Black Nylon Loop Arms Heavy-Duty Nylon Base <input type="checkbox"/> Dual Wheel Carpet Casters <input type="checkbox"/> Dimensions: Overall: 41"-45"(H) <input type="checkbox"/> Seat Size: 20" (W)X 19.5"(D) <input type="checkbox"/> Seat height: 17"-21"H <input type="checkbox"/> Back Size: 20" (W) X 26" (H) <input type="checkbox"/> Finish: Black <input type="checkbox"/> Black Nylon Loop Arms Heavy-Duty Nylon Base 		4	1,500.00	6,000.00
---	--	---	---	---	----------	----------

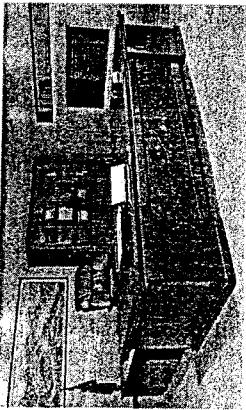
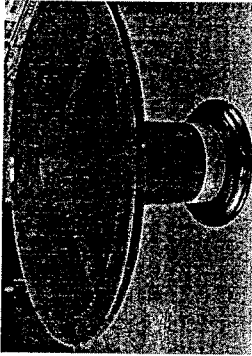
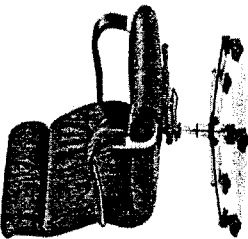

GROUND FLOOR WAITING AREA						
4	3 IN 1 SETTEE	<input type="checkbox"/> Material: leather <input type="checkbox"/> Polished wood <input type="checkbox"/> Comfortable and suitable for 3 people <input type="checkbox"/> Durable <input type="checkbox"/> Executive in nature <input type="checkbox"/> Colour: Black		3	5,700.00	17,100.00
5	EXECUTIVE 1.4M (3114) (Sound Room and Security Room)	<input type="checkbox"/> Material Make: Made of Hard Chip or Hard Fibre <input type="checkbox"/> First Grade <input type="checkbox"/> Polished Surface Finished <input type="checkbox"/> Size: 1.4M <input type="checkbox"/> Colour: Coffee Dark <input type="checkbox"/> Executive L-Shaped Office Desk With Chest of Drawers <input type="checkbox"/> L-Shaped and drawers are movable <input type="checkbox"/> Padded writing space <input type="checkbox"/> Material Make: Made of Hard Chip <input type="checkbox"/> First Grade <input type="checkbox"/> Polished wood with smooth surface <input type="checkbox"/> Durable <input type="checkbox"/> Size: 1.6M	  <p> 3114 B322 1.4M (L) \$4,800.00 3114 B322 1.4M (R) \$4,800.00 3114 B322 1.4M (C) \$4,800.00 3114 B322 1.4M (D) \$4,800.00 3114 B322 1.4M (E) \$4,800.00 3114 B322 1.4M (F) \$4,800.00 3114 B322 1.4M (G) \$4,800.00 3114 B322 1.4M (H) \$4,800.00 3114 B322 1.4M (I) \$4,800.00 3114 B322 1.4M (J) \$4,800.00 3114 B322 1.4M (K) \$4,800.00 3114 B322 1.4M (L) \$4,800.00 3114 B322 1.4M (M) \$4,800.00 3114 B322 1.4M (N) \$4,800.00 3114 B322 1.4M (O) \$4,800.00 3114 B322 1.4M (P) \$4,800.00 3114 B322 1.4M (Q) \$4,800.00 3114 B322 1.4M (R) \$4,800.00 3114 B322 1.4M (S) \$4,800.00 3114 B322 1.4M (T) \$4,800.00 3114 B322 1.4M (U) \$4,800.00 3114 B322 1.4M (V) \$4,800.00 3114 B322 1.4M (W) \$4,800.00 3114 B322 1.4M (X) \$4,800.00 3114 B322 1.4M (Y) \$4,800.00 3114 B322 1.4M (Z) \$4,800.00 </p>	3	2,800.00	8,400.00

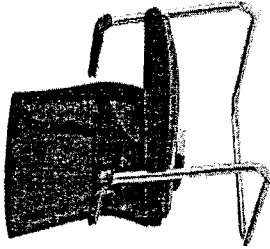

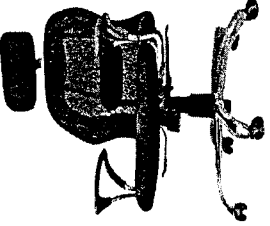
6	Executive 1.6M Desk (3116) (Reception)	<input type="checkbox"/> Material Make: Made of Hard Chip or Hard Fibre <input type="checkbox"/> First Grade <input type="checkbox"/> Polished Surface Finished <input type="checkbox"/> Size: 1.4M <input type="checkbox"/> Colour: Coffee Dark <input type="checkbox"/> Executive L-Shaped Office Desk With Chest of Drawers <input type="checkbox"/> L-Shaped and drawers are movable <input type="checkbox"/> Padded writing space <input type="checkbox"/> Material Make: Made of Hard Chip <input type="checkbox"/> First Grade <input type="checkbox"/> Polished wood with smooth surface <input type="checkbox"/> Durable <input type="checkbox"/> Size: 1.6M	 	1	3,700.00	3,700.00
7	CENTRE TABLE	<input type="checkbox"/> Glass Top <input type="checkbox"/> Rectangular in shape <input type="checkbox"/> Polished wood with smooth surface <input type="checkbox"/> Durable <input type="checkbox"/> Drawer Attached <input type="checkbox"/> Colour: Coffee		1	2,500.00	2,500.00
SMALL OFFICE-GROUND FLOOR						

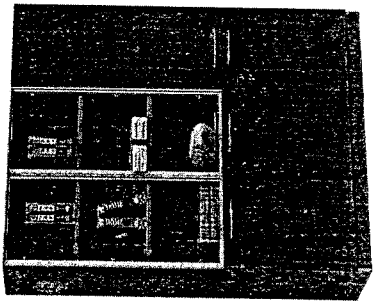
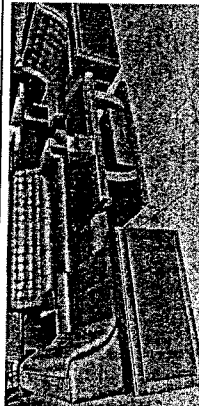
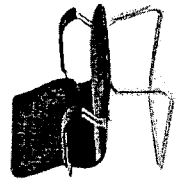
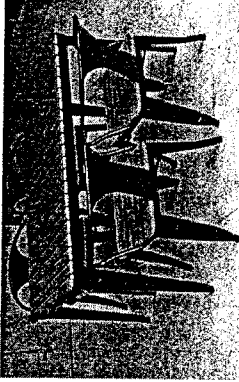

8	1.8M EXECUTIVE DESK (3018)	<input type="checkbox"/> Executive Straight Desk <input type="checkbox"/> Polished wood <input type="checkbox"/> Office Desk with Chest of Drawers <input type="checkbox"/> Movable Drawers <input type="checkbox"/> Material Make: Made of Hard Chip or Hard <input type="checkbox"/> First Grade <input type="checkbox"/> Dimension: 1.8M in length		3	4,200.00	12,600.00
9	EXECUTIVE ROUND TABLE	<input type="checkbox"/> Dimension is 1.500x1.500x800mm <input type="checkbox"/> Padded for writing <input type="checkbox"/> Colour: Coffee <input type="checkbox"/> Smooth Surface <input type="checkbox"/> Comfortable for writing <input type="checkbox"/> Scratch Resistance <input type="checkbox"/> Not Static/Movable		3	2,800.00	8,400.00
10	EXECUTIVE SWIVEL CHAIR- MB 19	<input type="checkbox"/> Leather Swivel chair <input type="checkbox"/> PU upholstery front back and seat <input type="checkbox"/> PVC backing <input type="checkbox"/> Chromed sleight frame <input type="checkbox"/> Adjustment height <input type="checkbox"/> Executive in nature <input type="checkbox"/> Durable and Comfortable <input type="checkbox"/> Colour: Black		3	3,200.00	9,600.00

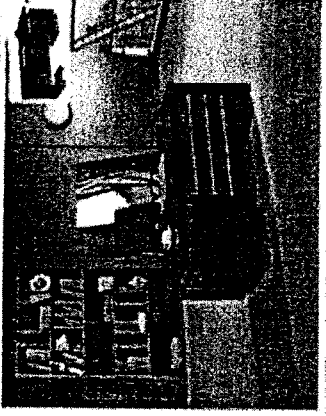
11	MESH VISITOR CHAIR- D3008	<input type="checkbox"/> Comfortable office chair with contoured mesh back for breathability <input type="checkbox"/> Pneumatic seat-height adjustment; padded seat for comfort <input type="checkbox"/> maximum weight capacity <input type="checkbox"/> Dimensions: 25.2 x 24 x 35.6-40.3 inches (DxWxH) <input type="checkbox"/> Leather Seat		12	1,100.00	13,200.00
12	Double Door Wooden Cabinet	<input type="checkbox"/> Bookshelves (Wooden) double Door <input type="checkbox"/> Dimension: 1600mm x 180mm <input type="checkbox"/> First Grade <input type="checkbox"/> Material Make: Hard Chip <input type="checkbox"/> 2 in 1 with glass doors Colour: Dark brown		3	2,400.00	7,200.00
13	SWIVEL CHAIR -MB 09)	<input type="checkbox"/> Office Swivel Chair <input type="checkbox"/> Black Vinyl Upholstery seat with Passive Lumber support Pneumatic Seat Height Adjustment <input type="checkbox"/> Black Nylon Loop Arms Heavy-Duty Nylon Base <input type="checkbox"/> Dual Wheel Carpet Casters <input type="checkbox"/> Arm rest <input type="checkbox"/> Dimension: 22.5" x 22" 33H		3	1,800.00	5,400.00
BIG OFFICES – GROUND FLOOR						
-						

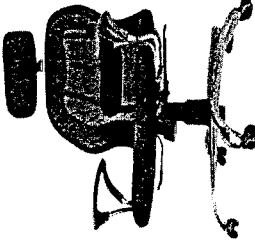
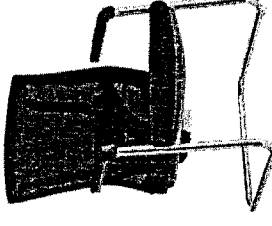

14	3 DOORS WOODEN CABINET	<input type="checkbox"/> Bookshelves (Wooden) double Door <input type="checkbox"/> Dimension: 1600mm x 180mm <input type="checkbox"/> First Grade <input type="checkbox"/> Material Make: Hard Chip <input type="checkbox"/> 3 in 1 with glass doors <input type="checkbox"/> Colour: Dark brown		2	3,200.00	6,400.00
15	OFFICE SOFA SET (3+1+1) (This sofa will be for the 2 offices that have being provided with desks by the school)	<input type="checkbox"/> High Quality Leather <input type="checkbox"/> High density cushion <input type="checkbox"/> Comfortable and durable <input type="checkbox"/> Polished wood at the outlet <input type="checkbox"/> Executive in Nature <input type="checkbox"/> Made Of: 3 Seater and 1 seater (1)		2	16,500.00	33,000.00
16	VISITORS CHAIR-MB 118	<input type="checkbox"/> Leather Visitor chair <input type="checkbox"/> PU upholstery front back and seat <input type="checkbox"/> PVC backing <input type="checkbox"/> Chromed sleight frame <input type="checkbox"/> Colour: Black		4	1,400.00	5,600.00
17	CAFETERIA SEATER - (4 Chairs with 1 Round/Rectangular table)	<input type="checkbox"/> Executive round Table <input type="checkbox"/> Mable Top with metal coded metal leg (1.2M)-(Round and rectangular) <input type="checkbox"/> Executive visitor Chair <input type="checkbox"/> Cushion with polished wood <input type="checkbox"/> Comfortable for long hours of meeting <input type="checkbox"/> Durable and small design		6	5,500.00	33,000.00
	BIG OPEN WAITING AREA					

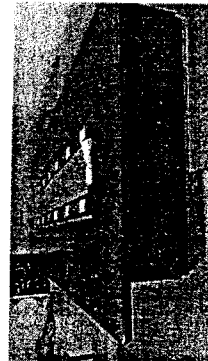
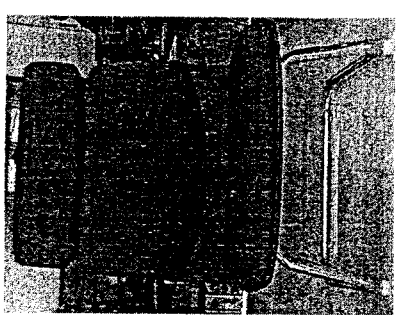
18A. SET OF 4 CHAIRS WITH TABLE (12 Tables & 48 chairs)		<input type="checkbox"/> Executive round Table <input type="checkbox"/> Marble Top with metal coded metal leg (1.2M)-(Round and rectangular) <input type="checkbox"/> Executive visitor Chair <input type="checkbox"/> Cushion with polished wood <input type="checkbox"/> Comfortable for long hours of meeting <input type="checkbox"/> Durable and well design		12	9,000.00	108,000.00
18B.	12 Tables & 48 chairs	NOTE: THIS IS FOR THE ABOVE (14) WE ARE SHOWING ANOTHER SAMPLE PICTURE				
19	LAB TECHNICAL OFFICE EXECUTIVE 1.4M DESK (3114)	<input type="checkbox"/> Executive L-Shaped Office Desk With Chest of Drawers <input type="checkbox"/> L-Shaped and drawers are movable <input type="checkbox"/> Padded writing space <input type="checkbox"/> Material Make: Made of Hard Chip <input type="checkbox"/> First Grade <input type="checkbox"/> Polished wood with smooth surface <input type="checkbox"/> Durable <input type="checkbox"/> Size: 1.4M		7	2,800.00	19,600.00

20	MESH SWIVEL CHAIR-MB 09	<input type="checkbox"/> Office Swivel Chair <input type="checkbox"/> Black Vinyl Upholstery seat with Passive Lumber support <input type="checkbox"/> Pneumatic Seat Height Adjustment <input type="checkbox"/> Black Nylon Loop Arms Heavy-Duty Nylon Base <input type="checkbox"/> Dual Wheel Carpet Casters <input type="checkbox"/> Arm rest <input type="checkbox"/> Dimension: 22.5" x 22" 33H		7	1,800.00	12,600.00
21	MESH VISITOR CHAIR- D3008	<input type="checkbox"/> Comfortable office chair with contoured mesh back for breathability <input type="checkbox"/> Pneumatic seat-height adjustment; padded seat for comfort <input type="checkbox"/> maximum weight capacity <input type="checkbox"/> Dimensions: 25.2 x 24 x 35.6-40.3 inches (DxWxH) <input type="checkbox"/> Fibre Seat		14	1,100.00	15,400.00
OPEN AREA 2nd FLOOR						
22	3 IN 1 SETTEE SETS (coffee area, different set up)	<input type="checkbox"/> Office Sofa: 3 in 1 <input type="checkbox"/> Size: (W88" x D38" x H36) <input type="checkbox"/> Colour: Black <input type="checkbox"/> Material: Wooden Frame with Original Leather <input type="checkbox"/> Durable and Comfortable <input type="checkbox"/> Executive in nature		6	5,700.00	34,200.00
SEMINAR ROOM-U FORM						

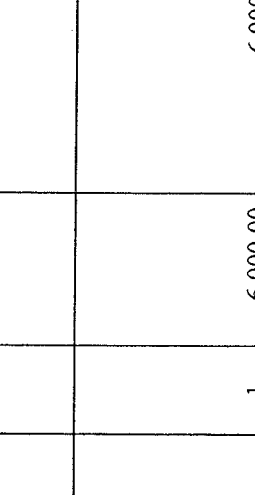
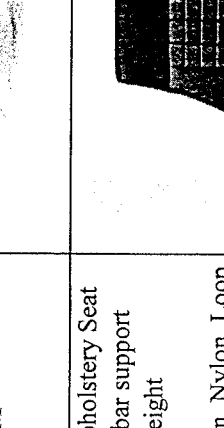
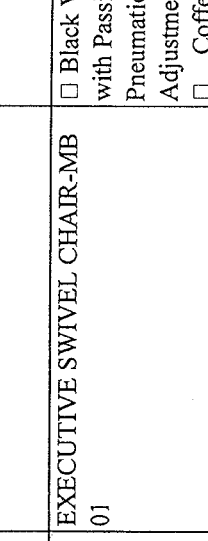
23	20 SEATER CONFERENCE TABLE	<input type="checkbox"/> Executive design <input type="checkbox"/> 6.5Meters dimensions <input type="checkbox"/> U in shape <input type="checkbox"/> Coffee in colour <input type="checkbox"/> Durable Wooden Table <input type="checkbox"/> Special Feature Suitable for Office, Computer, Laptop, General use		1	18,500.00	18,500.00
24	CONFERENCE CHAIRS-MB 114	<input type="checkbox"/> Fully upholstered in high grade black leather <input type="checkbox"/> Chrome base and chrome arms (metal arms) <input type="checkbox"/> Seat Height: (min-max) 450mm-530mm <input type="checkbox"/> Back width X Height: Medium Back 520 x 580mm <input type="checkbox"/> Back Width x Height High back: 520mm x 700mm <input type="checkbox"/> Seat Width x Depth: 520mm x 520mm <input type="checkbox"/> Seat Width x Depth: including arms: 630mm		20	1,450.00	29,000.00
25	SIDE CABINET	<input type="checkbox"/> Rectangular in shape <input type="checkbox"/> 1.6m Dimension <input type="checkbox"/> Durable <input type="checkbox"/> Smooth surface <input type="checkbox"/> Water resistant <input type="checkbox"/> Drawers and in build cabinet attached <input type="checkbox"/> Key locker		1	1,500.00	1,500.00
	DIRECTOR'S OFFICE-PROFESSOR					

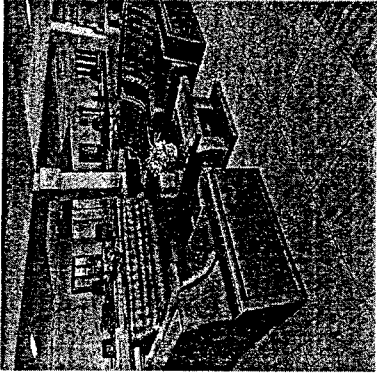
26	3.0M L-SHAPE DESK	<input type="checkbox"/> Executive L-Shaped Office Desk With Chest of Drawers <input type="checkbox"/> L-Shaped and drawers are movable <input type="checkbox"/> Padded writing space <input type="checkbox"/> Material Make: Made of Hard Chip <input type="checkbox"/> First Grade <input type="checkbox"/> Polished wood with smooth surface <input type="checkbox"/> Durable <input type="checkbox"/> Size: 2.4/ 3.0M		1	7,500.00	7,500.00
27	EXECUTIVE SWIVEL CHAIR-MB 01	<input type="checkbox"/> Black Vinyl Upholstery Seat with Passive Lumbar support <input type="checkbox"/> Pneumatic Seat Height Adjustment <input type="checkbox"/> Coffee Brown Nylon Loop Arms Heavy-Duty Nylon Base <input type="checkbox"/> Dual Wheel Carpet Casters <input type="checkbox"/> Dimensions: Overall: 41"-45"(H) <input type="checkbox"/> Seat Size: 20" (W)X 19.5"(D)		1	6,000.00	6,000.00
28	VISITOR CHAIR-MB 114	<input type="checkbox"/> Fully upholstered in high grade black leather <input type="checkbox"/> Chrome base and chrome arms (metal arms) <input type="checkbox"/> Seat Height: (min-max) 450mm-530mm <input type="checkbox"/> Back widthX Height: Medium Back 520 x 580mm <input type="checkbox"/> Back Width x Height High back: 520mm x 700mm <input type="checkbox"/> Seat Width x Depth: 520mm x 520mm <input type="checkbox"/> Seat Width x Depth: including arms: 630mm		3	1,450.00	4,350.00

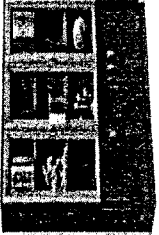
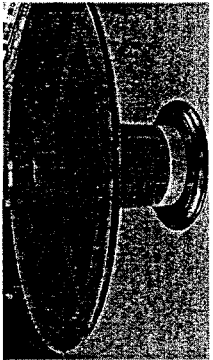
29	Sofa Set (3+2+1+1)	<input type="checkbox"/> High Quality Leather <input type="checkbox"/> High density cushion foam <input type="checkbox"/> Comfortable and durable <input type="checkbox"/> Polished wood at the outlet <input type="checkbox"/> Executive in Nature <input type="checkbox"/> Seven Seater Leather sofa <input type="checkbox"/> Colour: Brown / Black		1	27,500.00	27,500.00
30	Centre Table-A06	<input type="checkbox"/> Glass Top <input type="checkbox"/> Polished Wood with smooth surface <input type="checkbox"/> Rectangular in shape <input type="checkbox"/> Drawer attached <input type="checkbox"/> Durable <input type="checkbox"/> Executive in nature		1	2,550.00	2,550.00
31	5 DOOR WOODEN CABINET	<input type="checkbox"/> Bookshelves (Wooden) double Door <input type="checkbox"/> Dimension: 1600mm x 180mm <input type="checkbox"/> First Grade <input type="checkbox"/> Material Make: Hard Chip <input type="checkbox"/> 5 in 1 with glass doors <input type="checkbox"/> Colour: Dark brown		1	6,500.00	6,500.00
32	EXECUTIVE ROUND MEETING TABLE	<input type="checkbox"/> Made of Wood veneer <input type="checkbox"/> Durable <input type="checkbox"/> Anti-Water <input type="checkbox"/> Anti-Dirty <input type="checkbox"/> Anti-Scratch <input type="checkbox"/> Dimensions: 1500x1500x800mm <input type="checkbox"/> Writing padded surface <input type="checkbox"/> 4 Seater Executive Meeting		1	3,000.00	3,000.00

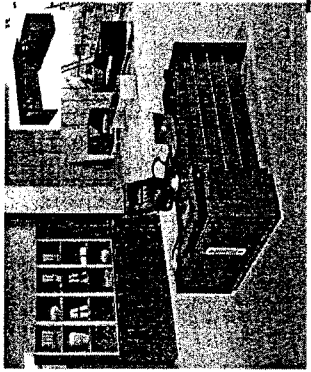
33	VISITORS CHAIRS -MB 114	<input type="checkbox"/> Fully upholstered in high grade black leather <input type="checkbox"/> Chrome base and chrome arms (metal arms) <input type="checkbox"/> Seat Height: (min-max) 450mm-530mm <input type="checkbox"/> Back width X Height: Medium Back 520 x 580mm <input type="checkbox"/> Back Width x Height High back: 520mm x 700mm <input type="checkbox"/> Seat Width x Depth: 520mm x 520mm <input type="checkbox"/> Seat Width x Depth: including arms: 630mm		4	1,450.00	5,800.00
	<i>DIRECTOR'S SECRETARIAT</i>					
34	1.4M L-SHAPE DESK	<input type="checkbox"/> Executive L-Shaped Office Desk With Chest of Drawers <input type="checkbox"/> L-Shaped and drawers are movable <input type="checkbox"/> Padded writing space <input type="checkbox"/> Material Make: Made of Hard Chip <input type="checkbox"/> First Grade <input type="checkbox"/> Polished wood with smooth surface <input type="checkbox"/> Durable <input type="checkbox"/> Size: 1.4M		2	2,300.00	4,600.00

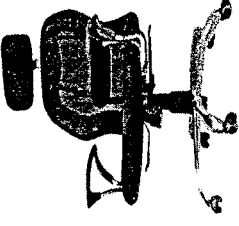
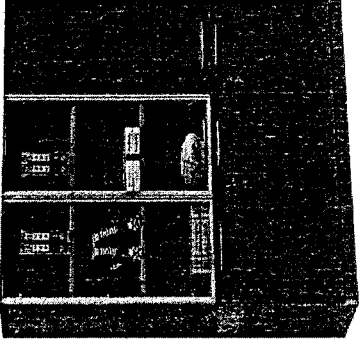
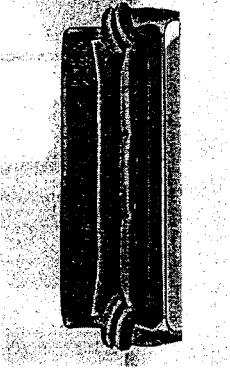
35	SWIVEL CHAIR-MB 09	<input type="checkbox"/> Office Mesh Swivel Chair <input type="checkbox"/> Black Vinyl Upholstery seat with Passive Lumber support <input type="checkbox"/> Pneumatic Seat Height Adjustment <input type="checkbox"/> Black Nylon Loop Arms <input type="checkbox"/> Heavy-Duty Nylon Base <input type="checkbox"/> Dual Wheel Carpet Casters		2	1,800.00	3,600.00
36	3 DOOR WOODEN CABINET	<input type="checkbox"/> Bookshelves (Wooden) double Door <input type="checkbox"/> Dimension: 1200mm x 180mm <input type="checkbox"/> First Grade <input type="checkbox"/> Material Make: Hard Chip <input type="checkbox"/> 3 in 1 with glass doors <input type="checkbox"/> Colour: Dark brown		1	3,200.00	3,200.00
37	EXECUTIVE 3 SEATER SOFA	<input type="checkbox"/> Office Sofa: 3 in 1 <input type="checkbox"/> Size: (W88" x D38" x H36) <input type="checkbox"/> Colour: Black <input type="checkbox"/> Material: Wooden Frame with Original Leather <input type="checkbox"/> Durable and Comfortable <input type="checkbox"/> Executive in nature		3	5,700.00	17,100.00

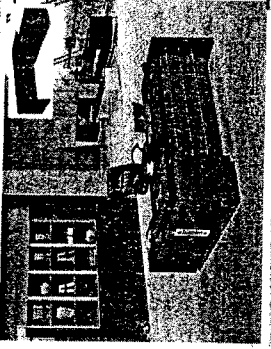
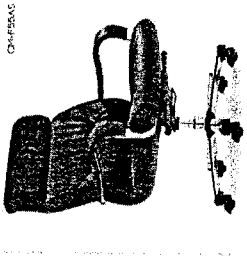
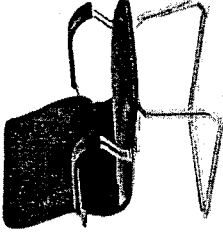
38	Executive 1.8M DESK (3018) (Assistant Registrar)	<input type="checkbox"/> Office Desk with Chest of Drawers <input type="checkbox"/> Material Make: Made of Hard Chip <input type="checkbox"/> First Grade <input type="checkbox"/> Colour: Coffee <input type="checkbox"/> Straight Desk with Smooth Surface <input type="checkbox"/> Size: 1.8M		1	4,200.00	4,200.00
39	SWIVEL CHAIR-MB 19	<input type="checkbox"/> Executive Swivel Chair <input type="checkbox"/> Black Vinyl Upholstery seat with Passive Lumber support Pneumatic Seat Height Adjustment <input type="checkbox"/> Black Nylon Loop Arms Heavy-Duty Nylon Base <input type="checkbox"/> Dual Wheel Carpet Casters <input type="checkbox"/> Arm and Head rest <input type="checkbox"/> Executive in nature <input type="checkbox"/> Dimension: 22.5" x 22" 33H		1	3,500.00	3500
40	SWIVEL CHAIR-MB 118	<input type="checkbox"/> Arm Rest with Cum Leather <input type="checkbox"/> Fully upholstered in high grade black leather. High back rest <input type="checkbox"/> Leather Visitor chair <input type="checkbox"/> PU upholstery front back and seat <input type="checkbox"/> PVC backing <input type="checkbox"/> Durable <input type="checkbox"/> Chromed sleight frame <input type="checkbox"/> Colour: Black		2	1,450.00	2,900.00

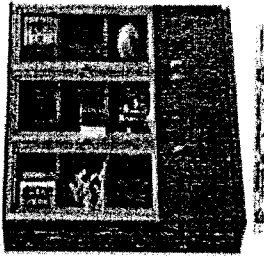
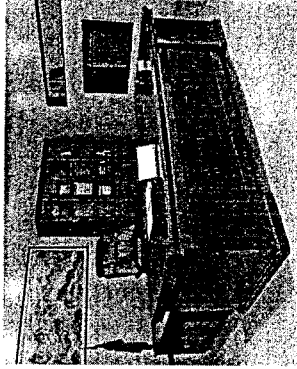
41	3 WOODEN CABINET	<input type="checkbox"/> Bookshelves (Wooden) double Door <input type="checkbox"/> Dimension: 1200mm x 180mm <input type="checkbox"/> First Grade <input type="checkbox"/> Material Make: Hard Chip <input type="checkbox"/> 3 in 1 with glass doors <input type="checkbox"/> Colour: Dark brown		2	3,200.00	6,400.00
BIG OFFICE- 2ND FLOOR						
42	2M EXECUTIVE L-SHAPE DESK (DEPUTY DIRECTOR)	<input type="checkbox"/> Executive L-Shaped Office Desk With Chest of Drawers <input type="checkbox"/> L-Shaped and drawers are movable <input type="checkbox"/> Padded writing space <input type="checkbox"/> Material Make: Made of Hard Chip <input type="checkbox"/> First Grade <input type="checkbox"/> Polished wood with smooth surface <input type="checkbox"/> Durable <input type="checkbox"/> Size: 2.0M		1	5,000.00	5,000.00

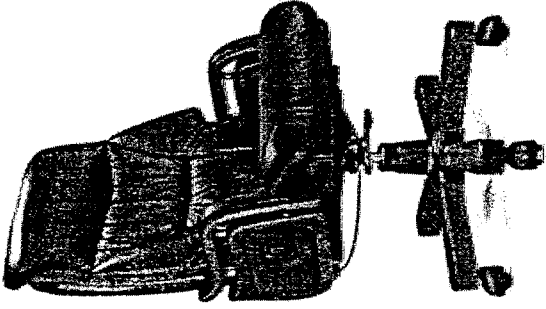
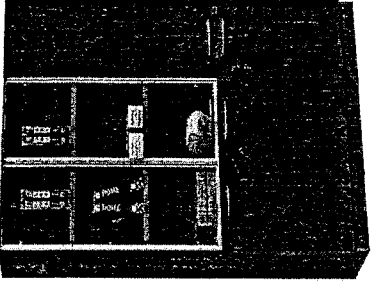
43	<p>SWIVEL CHAIR-MB 25</p> <ul style="list-style-type: none"> <input type="checkbox"/> Black Vinyl Upholstery Seat with Passive Lumbar support Pneumatic Seat Height Adjustment <input type="checkbox"/> Black Nylon Loop Arms Heavy-Duty Nylon Base <input type="checkbox"/> Dual Wheel Carpet Casters <input type="checkbox"/> Dimensions: Overall: 41" - 45"(H) <input type="checkbox"/> Seat Size: 20" (W) X 19.5"(D) <input type="checkbox"/> Seat height: 17"-21"H <input type="checkbox"/> Back Size: 20" (W) X 26" (H) <input type="checkbox"/> Finish: Black Vinyl <input type="checkbox"/> Black Nylon Loop Arms Heavy-Duty Nylon Base <input type="checkbox"/> Dual Wheel Carpet Casters <input type="checkbox"/> Armrest 		1	5,000.00
44	<p>3 DOOR CABINET</p> <ul style="list-style-type: none"> <input type="checkbox"/> Bookshelves (Wooden) double Door <input type="checkbox"/> Dimension: 1200mm x 180mm <input type="checkbox"/> First Grade <input type="checkbox"/> Material Make: Hard Chip <input type="checkbox"/> 3 in 1 with glass doors <input type="checkbox"/> Colour: Dark brown 		1	3,200.00

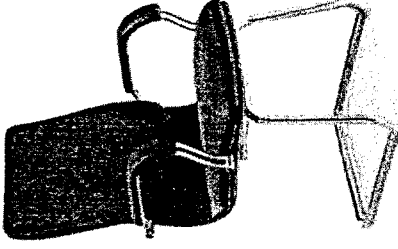
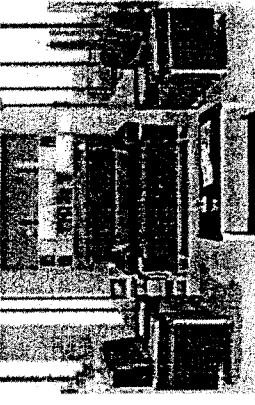
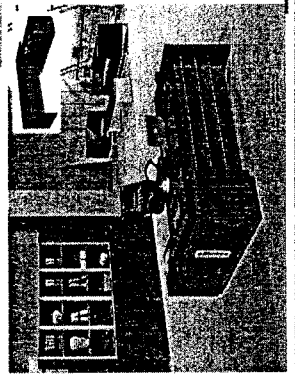
45	VISITORS CHAIR-MB 118	<input type="checkbox"/> Fully upholstered in high grade black leather <input type="checkbox"/> Chrome base and chrome arms (metal arms) <input type="checkbox"/> Seat Height: (min-max) 450mm-530mm <input type="checkbox"/> Back width X Height: Medium Back 520 x 580mm <input type="checkbox"/> Back Width x Height High back: 520mm x 700mm <input type="checkbox"/> Seat Width x Depth: 520mm x 520mm <input type="checkbox"/> Seat Width x Depth: including arms: 630mm		2	1,450.00	2,900.00
46	5 SEATER EXECUTIVE SOFA (3+1+1)-107	<input type="checkbox"/> Office Sofa: 3 +1+1 <input type="checkbox"/> Size: (W88" x D38" x H36) <input type="checkbox"/> Colour: Black <input type="checkbox"/> Material: Wooden Frame with Original/Pure Leather <input type="checkbox"/> Durable and Comfortable <input type="checkbox"/> Suitable for 5 People <input type="checkbox"/> Executive in nature		1	14,500.00	14,500.00
	SECRETARY TO THE DEPUTY DIRECTOR					
47	1.4M L SHAPE DESK	<input type="checkbox"/> Executive L-Shaped Office Desk With Chest of Drawers <input type="checkbox"/> L-Shaped and drawers are movable <input type="checkbox"/> Padded writing space <input type="checkbox"/> Material Make: Made of Hard Chip <input type="checkbox"/> First Grade <input type="checkbox"/> Polished wood with smooth surface <input type="checkbox"/> Durable <input type="checkbox"/> Size: 1.4M		1	2,300.00	2,300.00

UNIVERSITY OF ENERGY AND NATURAL RESOURCES (UENR), SUNYANI

MINUTES OF TENDER EVALUATION PANEL (TEP) MEETING HELD ON WEDNESDAY, 5TH OCTOBER, 2022 AT THE GETFUND HOSTEL'S CONFERENCE ROOM, UENR

A. PRESENT

1. Prof. Simon Abugre	Dean, School of Natural Resources	Chairman
2. Mr. John-Baptist Siddick	Ag. Director of Procurement	Member
3. Mr. Paul Nana Nketiah	Deputy Director of Finance	Member
4. Mr. Ebenezer T. Lanor	Transport Engineer	Member
5. Mr. Kwaku O. Mireku	Estate Officer	Member
6. Mr. Kofi Dwomoh	Principal Procurement Assistant	Secretary

1.0 OPENING

The meeting started at 10.30 p.m. with a prayer by the Chairman, Prof. Simon Abugre. The Chairman then welcomed the Panel Members and briefed them on the purpose of the meeting, which was to evaluate the following tenders;

S/No. 1: Procurement of 4 x 4 SUV Vehicle for the Regional Centre for Energy and Environmental Sustainability (RCEES), UENR

S/No. 2: Procurement of Furniture for the Regional Centre for Energy and Environmental Sustainability (RCEES), UENR:

Lot 2A: Office Furniture,

Lot 2B: Auditorium Furniture,

Lot 2C: Lecture Hall Furniture,

Lot 2D: Laboratory Furniture.

At this stage, the Chairman asked the Team from Procurement Directorate to take members through the Evaluation Process.

2.0 MAIN BUSINESS: NATIONAL COMPETITIVE TENDERS

- (i) ***S/No. 1: Procurement of 4 x 4 SUV Vehicle for the Regional Centre for Energy and Environmental Sustainability (RCEES), UENR***

One (1) firm, namely: **Klataa Engineering Solutions Limited** submitted tender.

The Submissions were as follows;

- (i) Klataa Engineering Solutions Limited - GH¢ 1,740,000.00

The firm was however disqualified because they submitted an Official Receipt instead of Clearance Certificate from SSNIT as requested.

Recommendations:

There was no Recommendation for Award of Contract.

(ii) *S/No. 2: Procurement of Furniture for the Regional Centre for Energy and Environmental Sustainability (RCEES), UENR: Lot 2A: Office Furniture*

Three (3) firms, namely: **Mat-Bans Company Limited; Contra-Focus Limited; and Yekna Investment Limited** submitted tenders.

The Submissions were as follows;

- (i) Mat-Bans Company Limited- GH¢1,390,250.00
- (ii) Contra-Focus Limited - GH¢1,897,672.00
- (iii) Yekna Investment Limited - GH¢1,103,492.00

The underlisted firms were not substantially responsive based on the following reasons:

- a. **Contra-Focus Limited** was not responsive because the List of references provided by the firm were not related to Office Furniture.
- b. **Yekna Investment Limited** was not responsive because of the following reasons;
 - The firm did not provide information on payment terms as requested.
 - The firm did not provide Audited Financial Accounts for 2020 and 2021 as requested

Recommendations:

On the basis of the evaluation which was carried out in accordance with the Tender Documents, the Panel recommended the acceptance of **Mat-Bans Company Limited** at a total Tender Price of **GH¢1,390,250.00**

(iii) *Procurement of Furniture for the Regional Centre for Energy and Environmental Sustainability (RCEES), UENR: Lot 2B: Auditorium Furniture,*

Two (2) firms, namely: **Mat-Bans Company Limited; and Contra-Focus Limited** submitted tenders.

The Submissions were as follows;

- (i) Mat-Bans Company Limited- GH¢236,850.00
- (ii) Contra-Focus Limited - GH¢428,480.00

Contra-Focus Limited was not substantially responsive because List of references provided by the firm were not related to Auditorium Furniture.

Recommendations:

On the basis of the evaluation which was carried out in accordance with the Tender Documents, the Panel recommended acceptance of **Mat-Bans Company Limited** at a total Tender Price of **GH¢236,850.00**.

(iv) *Procurement of Furniture for the Regional Centre for Energy and Environmental Sustainability (RCEES), UENR: Lot 2C: Lecture Hall Furniture.*

Four (4) firms, namely: **White Pleasure Company Limited; Mat-Bans Company Limited; Contra-Focus Limited; and Yekna Investment Limited** submitted tenders

The Submission was as follows;

- (i) White Pleasure Company Limited - GH¢1,054,706.63

- (ii) Mat-Bans Company Limited- GH¢818,800.00
- (iii) Contra-Focus Limited - GH¢880,238.00
- (iv) Yekna Investment Limited - 1,707,576.00

The underlisted firms were not substantially responsive based on the following reasons:

- a. **White Pleasure Company Limited** was not responsive because the firm's proposed Lecture Hall Furniture did not meet our Technical Requirement.
- b. **Contra-Focus Limited** was not responsive because the List of References they provided were not related to Lecture Hall Furniture.
- c. **Yekna Investment Limited** was not responsive because of the following reasons;
 - They did not provide information on the Payment Terms requirement as requested.
 - They did not provide Audited Financial Accounts for 2020 and 2021 as requested

Recommendations:

On the basis of the evaluation which was carried out in accordance with the Tender Documents, the Panel recommended acceptance of **Mat-Bans Company Limited** at a total Tender Price of **GH¢818,800.00**.

- (v) *Procurement of Furniture for the Regional Centre for Energy and Environmental Sustainability (RCEES), UENR: Lot 2C: Lecture Hall Furniture.*

Three (3) firms, namely: **White Pleasure Company Limited; Mat-Bans Company Limited; and Contra-Focus Limited** submitted tenders

The Submission was as follows;

- (i) White Pleasure Company Limited - GH¢116,388.00
- (ii) Mat-Bans Company Limited- GH¢134,900.00
- (iii) Contra-Focus Limited - GH¢120,510.00

Contra-Focus Limited was not substantially responsive because the List of References that the firm provided were not related to Office Furniture

Recommendations:

On the basis of the evaluation which was carried out in accordance with the Tender Documents, the Panel recommended acceptance of **White Pleasure Company Limited** at a total Tender Price of **GH¢116,388.00**.

3.0 ADJOURNMENT

The Chairman expressed appreciation to the Panel for their time, participation, and contribution to the Evaluation Process. The meeting ended at 2.50 p.m.



.....
Prof. Simon Abugre

Date: 05/10/2022



.....
Mr. Kofi Dwomoh

Date: 05/10/2022







UNIVERSITY OF ENERGY AND NATURAL RESOURCES (UENR), SUNYANI

TENDER EVALUATION PANEL (TEP) MEETING (NATIONAL COMPETITIVE TENDER, NCT) FOR THE PROCUREMENT OF 4 X 4 SUV VEHICLE FOR THE REGIONAL CENTRE FOR ENERGY AND ENVIRONMENTAL SUSTAINABILITY (RCEES), UENR; AND PROCUREMENT OF FURNITURE FOR THE REGIONAL CENTRE FOR ENERGY AND ENVIRONMENTAL SUSTAINABILITY (RCEES), UENR: LOT 2A: OFFICE FURNITURE, LOT 2B: AUDITORIUM FURNITURE, LOT 2C: LECTURE HALL FURNITURE, AND LOT 2D: LABORATORY FURNITURE

ATTENDANCE LIST (AFTERNOON SESSION)

5TH OCTOBER, 2022

10:00 AM

NO.	NAME	DESIGNATION	SIGNATURE	TEL NO.
1	Prof. Simon Abugn	Chairman		0209500070
2	John Baptist Seldu	member		0209535863
3	Paul Nana Meechieh	member		0240158484
4.	Ebenzer T. barua	Member		0206954930
5	Kwaku O. Mireku	Member		020546829
6	Kofi Bwomb	Secretary		0208760049





UNIVERSITY OF ENERGY AND NATURAL RESOURCES (UENR), SUNYANI

TENDER OPENING PANEL (TEP) MEETING (NATIONAL COMPETITIVE TENDER, NCT) FOR THE PROCUREMENT OF 4 X 4 SUV VEHICLE FOR THE REGIONAL CENTRE FOR ENERGY AND ENVIRONMENTAL SUSTAINABILITY (RCEES), UENR; PROCUREMENT OF FURNITURE FOR THE REGIONAL CENTRE FOR ENERGY AND ENVIRONMENTAL SUSTAINABILITY (RCEES), UENR: LOT 2A: OFFICE FURNITURE, LOT 2B: AUDITORIUM FURNITURE, LOT 2C: LECTURE HALL FURNITURE, LOT 2D: LABORATORY FURNITURE

ATTENDANCE LIST-TENDERERS

20TH SEPTEMBER, 2022

11:00 AM

NO.	NAME	COMPANY	SIGNATURE	TEL NO.
1	Emmanuel Adofo	MAT-BANS CO. LTD		0243201585
2	Emmanuel Terkyey Gyasi	White Pleasure		0246183678
3	Eric Oryere	CONTRA - Focus Ltd.		0244579287
4	Mildred Asabey	YEKNA INVESTMENTS LTD		0264272385
5	Anthony Oumeh	YEKNA INVESTMENTS		0244272385







UNIVERSITY OF ENERGY AND NATURAL RESOURCES (UENR), SUNYANI

TENDER OPENING PANEL (TEP) MEETING (NATIONAL COMPETITIVE TENDER, NCT) FOR THE PROCUREMENT OF 4 X 4 SUV VEHICLE FOR THE REGIONAL CENTRE FOR ENERGY AND ENVIRONMENTAL SUSTAINABILITY (RCEES), UENR; PROCUREMENT OF FURNITURE FOR THE REGIONAL CENTRE FOR ENERGY AND ENVIRONMENTAL SUSTAINABILITY (RCEES), UENR: LOT 2A: OFFICE FURNITURE, LOT 2B: AUDITORIUM FURNITURE, LOT 2C: LECTURE HALL FURNITURE, LOT 2D: LABORATORY FURNITURE

ATTENDANCE LIST-STAFF

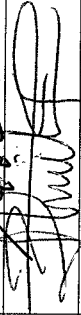
20TH SEPTEMBER, 2022

11:00 AM

NO.	NAME	DESIGNATION	SIGNATURE	TEL NO.
1	Prof. Simon Abouge	Chairman		0209500020
2	John Baptist Sidi	member		0244535464
3	Paul Nwankechi	member		0240458484
4	Ebenezer T. Leorin	Member		0246954930
5	Francis Ampomah-Djan	Member		0246167445
6	Kofi Swomoh	Secretary		0208360049

UNIVERSITY OF ENERGY AND NATURAL RESOURCES (UENR), SUNYANI

MINUTES OF THE TENDER OPENING PANEL MEETING FOR NATIONAL COMPETITIVE TENDERING (NCT); PROCUREMENT OF 4 x 4 SUV VEHICLE AND FURNITURE FOR THE REGIONAL CENTRE FOR ENERGY AND ENVIRONMENTAL SUSTAINABILITY (RCEES), UENR HELD ON 20TH SEPTEMBER, 2022 AT THE COUNCIL CHAMBER - UENR

MEMBERS PRESENT

1. Prof. Simon Abugre	Dean, School of Natural Resources	Chairman
2. Mr. John-Baptist Siddick	Ag. Director of Procurement	Member
3. Mr. Paul Nana Nketiah	Deputy Director of Finance	Member
4. Mr. Ebenezer T. Lanor	Transport Engineer	Member
5. Mr. Francis Amponsah-Djan	Rep. for Estate Officer	Member
6. Mr. Kofi Dwomoh	Principal Procurement Assistant	Secretary

IN- ATTENDANCE

A. TENDERERS

1. Mr. Emmanuel Adofo	Mat-Bans Company Limited
2. Mr. Emmanuel T. Cyrus	White Pleasure Company Limited
3. Mr. Eric Okyere	Contra-Focus Limited
4. Mr. Anthony Owusu	Yekna Investment Limited
5. Ms. Mildred Assibey	Yekna Investment Limited

1.0 OPENING

The meeting started with a prayer by Mr. Ebenezer T. Lanor after close of tender submission at 11: 00 am. The Chairman welcomed the Tender Opening Committee Members and tenderers representatives who were present at the tender opening and briefed them on the purpose of the meeting, which were to open the following tenders;

- (i) S/No. 1: Procurement of 4 x 4 SUV Vehicle for the Regional Centre for Energy and Environmental Sustainability (RCEES), UENR.
- (ii) S/No. 2: Procurement of Furniture for the Regional Centre for Energy and Environmental Sustainability (RCEES), UENR:
 - Lot 2A: Office Furniture,
 - Lot 2B: Auditorium Furniture,
 - Lot 2C: Lecture Hall Furniture,
 - Lot 2D: Laboratory Furniture.

UNIVERSITY OF ENERGY AND NATURAL RESOURCES (UENR), SUNYANI

The Chairman further informed the Committee and tenderers representatives that, the tender opening session was just the first stage of the tendering process and assured the tenderers of open, transparent and fair process. There was a self-introduction session by all tender Opening Panel Members and Tenderers present.

2.0 OPENING OF TENDER BOX

The locked tender box in which tenderer(s) had deposited their tender was opened in the presence of the Tender Opening Panel and tenderer's representatives who attended the tender opening.

The following Seven (7) Suppliers responded to our advert and purchased the Tender Documents;

1. Toyota Ghana Company Limited, Accra
2. Sneda Motors, Accra
3. Klataa Engineering Solutions Company Limited, Accra
4. Mat-Bans Company Limited, Accra
5. White Pleasure Company Limited, Accra
6. Contra-Focus Limited, Accra
7. Yekna Investment Limited, Accra

However, at the time for the closure of the tender submission, five (5) suppliers submitted their tender documents for the various packages. The suppliers were;

1. Klataa Engineering Solutions Company Limited, Accra
2. Mat-Bans Company Limited, Accra
3. White Pleasure Company Limited, Accra
4. Contra-Focus Limited, Accra
5. Yekna Investment Limited, Accra

3.0 SUBMISSION OF PRELIMINARY REQUIREMENTS

The preliminary requirement indicated in the tender document which the tenderers were required to submit or comply with and their tender prices were read before the tender opening panel and the representatives of tenderers who attended the tender opening meeting.

The requirements indicated in the tender document were as follows:

UNIVERSITY OF ENERGY AND NATURAL RESOURCES (UENR), SUNYANI

- Tender Signed
- Business Registration Certificate
- Valid Tax Clearance Certificate
- Valid SSNIT Clearance Certificate
- VAT Registration Certificate
- Tender Security 2% of Total Tender price
- Public Procurement Authority (PPA) Registration

The tender documents of the tenderers were examined by the committee regarding compliance with these requirements.

UNIVERSITY OF ENERGY AND NATURAL RESOURCES (UENR), SUNYANI

(i) S/No. 1: Procurement of 4 x 4 SUV Vehicle for the Regional Centre for Energy and Environmental Sustainability (RCEES), UENR.

No.	Name of Tenderer(s)	Tender Signed	Business Reg. cert	VAT certificate	Valid Tax Clearance Cert	Valid SSNIT Clearance Cert	PPA Reg. Cert	Tender Security-Bond or Bank Guarantee (2% of Tender Price)	Total Tender price (read-out)
1	Klataa Engineering Solutions Company Limited	√	√	√	√	x	√	√ Bid Bond from Star Assurance GH¢40,000.00	GH¢1,740,000.00

√: Means tenderer(s) submitted the requirement

x: Means tenderer(s) did not submit the requirement

**(ii) S/No. 2: Procurement of Furniture for the Regional Centre for Energy and Environmental Sustainability (RCEES), UENR:
Lot 2A: Office Furniture**

No.	Name of Tenderer(s)	Tender Signed	Business Reg. cert	VAT certificate	Valid Tax Clearance Cert	Valid SSNIT Clearance Cert	PPA Reg. Cert	Tender Security-Bond or Bank Guarantee (2% of Tender Price)	Total Tender price (read-out)
1	Mat-Bans Company Limited	√	√	√	√	√	√	√ Bid Bond from Phoenix Insurance GH¢51,620.00	GH¢1,390,250.00
2	Contra-Focus Limited	√	√	√	√	√	√	√ Bid Bond from SIC Insurance GH¢73,000.00	GH¢1,897,672.00
3	Yekna Investment Limited	√	√	√	√	√	√	√ Bid Bond from Phoenix Insurance GH¢25,000.00	GH¢1,103,492.00

√: Means tenderer(s) submitted the requirement

x: Means tenderer(s) did not submit the requirement

UNIVERSITY OF ENERGY AND NATURAL RESOURCES (UENR), SUNYANI

**(iii) S/No. 2: Procurement of Furniture for the Regional Centre for Energy and Environmental Sustainability (RCEES), UENR:
Lot 2B: Auditorium Furniture**

No.	Name of Tenderer(s)	Tender Signed	Business Reg. cert	VAT certificate	Valid Tax Clearance Cert	Valid SSNIT Clearance Cert	PPA Reg. Cert	Tender Security (2% of Tender Price)	Total Tender price (read-out)
1	Mat-Bans Company Limited	√	√	√	√	√	√	Bid Bond from Phoenix Insurance GH¢51,620.00	GH¢236,850.00
2	Contra-Focus Limited	√	√	√	√	√	√	Bid Bond from SIC Insurance GH¢73,000.00	GH¢428,480.00

√: Means tenderer(s) submitted the requirement

x: Means tenderer(s) did not submit the requirement

**(iv) S/No. 2: Procurement of Furniture for the Regional Centre for Energy and Environmental Sustainability (RCEES), UENR:
Lot 2C: Lecture Hall Furniture**

No.	Name of Tenderer(s)	Tender Signed	Business Reg. cert	VAT Certificate	Valid Tax Clearance Cert	Valid SSNIT Clearance Cert	PPA Reg. Cert	Tender Security (2% of Tender Price)	Total Tender price (read-out)
1	White Pleasure Company Limited	√	√	√	√	√	√	Bid Bond from Holland Insurance GH¢23,421.89	GH¢1,054,706.63
2	Mat-Bans Company Limited	√	√	√	√	√	√	Bid Bond from Phoenix Insurance GH¢51,620.00	GH¢818,800.00
3	Contra-Focus Limited	√	√	√	√	√	√	Bid Bond from SIC Insurance GH¢73,000.00	GH¢880,238.00
4	Yekna Investment Limited	√	√	√	√	√	√	Bid Bond from Phoenix Insurance GH¢40,000.00	GH¢1,707,576.00

√: Means tenderer(s) submitted the requirement

x: Means tenderer(s) did not submitted the requirement

UNIVERSITY OF ENERGY AND NATURAL RESOURCES (UENR), SUNYANI

(iv) S/No. 2: Procurement of Furniture for the Regional Centre for Energy and Environmental Sustainability (RCEES), UENR:
 Lot 2D: Laboratory Furniture

No.	Name of Tenderer(s)	Tender Signed	Business Reg. cert	VAT Certificate	Valid Tax Clearance Cert	Valid SSNIT Clearance Cert	PPA Reg. Cert	Tender Security (2% of Tender Price)	Total Tender price (read-out)
1	White Pleasure Company Limited	√	√	√	√	√	√	Bid Bond from Hollard Insurance GH¢23,421.89	GH¢116,388.00
2	Mat-Bans Company Limited	√	√	√	√	√	√	Bid Bond from Phoenix Insurance GH¢51,620.00	GH¢134,900.00
3	Contra-Focus Limited	√	√	√	√	√	√	Bid Bond from SIC Insurance GH¢73,000.00	GH¢120,510.00

4.0 ADJOURNMENT

The Chairman thanked the tender opening panel and the representatives of tenderers for attending the meeting. The meeting ended with a prayer by Mr. Francis Amponsah-Djan at 2:20 p.m.

CHAIRMAN



.....
Prof. Simon Abugre

Date: 20/09/2022

SECRETARY



.....
Mr. Kofi Dwomoh

Date: 20/09/2022

UNIVERSITY OF ENERGY AND NATURAL RESOURCES
TENDER OPENING CHECKLIST

DATE: 20TH SEPTEMBER, 2022

PROCUREMENT METHOD: NATIONAL COMPETITIVE TENDER

CONTRACT NAME: S/NO 2: PROCUREMENT OF FURNITURE FOR THE REGIONAL CENTRE FOR ENERGY AND ENVIRONMENTAL SUSTAINABILITY (RCEES), UENR:

LOT 2A: OFFICE FURNITURE, LOT 2B: AUDITORIUM FURNITURE, LOT 2C: LECTURE HALL FURNITURE, LOT 2D: LABORATORY FURNITURE
CONTRACT PACKAGE NO.: BA/UENR/GD/006/22, BA/UENR/GD/009/22
(BA/UENR/RCEES/GD/007/22)

NO.	TENDERER'S NAME	DS	CERTIFICATES				BID SECURITY (2%)	TENDER PRICE (GH¢)	REMARKS
			BRC	VAT	SSNIT	TAX			
1	WHITE PLEASURE COMPANY LIMITED	✓	✓	✓	19/10/2022	✓	2319/2022	Lot 2A: 1700000 Lot 2B: 23,421.89 Lot 2C: 1,054,706.03 Lot 2D: 116,388.00	
2	MAT-BANS COMPANY LIMITED	✓	✓	✓	16/10/2022	✓	01/9/2023	PHOENIX 57,620.00 Lot 2A: 1,350,200.00 Lot 2B: 236,850.00 Lot 2C: 818,800.00 Lot 2D: 124,900.00	
3	CONTRA-FOCUS LIMITED	✓	✓	✓	23/9/2022	✓	22/9/2023	SIC 73,000.00 Lot 2A: 1,894,672.00 Lot 2B: 428,480.00 Lot 2C: 880,238.00 Lot 2D: 120,810.00	
4	YEKWA INVESTMENT LIMITED	✓	✓	✓	29/9/2022	✓	7/11/2022	PHOENIX 25,000 40,000 Lot 2A: 1,103,492.00 Lot 2B: 1,701,576.00 Lot 2D: 1,701,576.00	

CHAIRMAN
DATE: 20/9/2022

SECRETARY
DATE: 20/9/2022

KEY

- DS-Document Signed
- VAT-Value Added Tax Certificate
- BRC- Business Registration Certificate
- TAX-Valid Tax Clearance Certificate
- SSNIT-Valid SSNIT Clearance Certificate
- PPA-Public Procurement Authority Registration Certificate

TENDER OPENING COMMITTEE MEMBERS

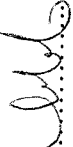
1. Name... Prof. Simon Abugre
Designation... Chairman
Signature... 

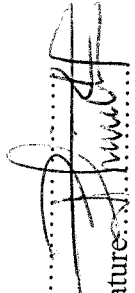
3. Name... Paul Nana Nketiah
Designation... Member
Signature... 

5. Name... Kofi Essomiek
Designation... Secretary
Signature... 

7. Name.....
Designation.....
Signature.....

2. Name... Francis Ampomah-Djan
Designation... Member
Signature... 

4. Name... John Baptist Siddig
Designation... Member
Signature... 





6. Name.....
Designation.....
Signature.....

8. Name.....
Designation.....
Signature.....

UNIVERSITY OF ENERGY AND NATURAL RESOURCES, SUNYANI

TENDER DOCUMENTS PURCHASE REGISTER

S/NO 2: PROCUREMENT OF FURNITURE FOR THE REGIONAL CENTRE FOR ENERGY AND ENVIRONMENTAL SUSTAINABILITY (RCEES), UENR: LOT 2C: LECTURE HALL FURNITURE

NO.	NAME OF COMPANY	NAME OF REPRESENTATIVE	DATE	TIME	TEL. NO.	RECEIPT NO.	SIGNATURE
1.	Compq-focus	James Osei Tutu	7/9/22	2:57	0244278105	77711	
2.	Mat-Bars	Newman Aranning	8/9/22	10:14	0208280717	77713	
3.	White Pleasure	Emmanuel Cyrus	8/9/22	11:02	0272074662	77714	
4.	YEROKA INVESTMENT	ALE PETER	8/9/22	4:18	024427230	07284	
5.							
6.							
7.							
8.							
9.							
10.							



'Heavy fighting' as Ukraine seeks to retake Kherson

FIERCE battles have been reported as Ukraine tries to retake the Russian-occupied southern Kherson region - but military experts have told the BBC it "won't happen quickly".

"Heavy fighting is continuing, our soldiers are working around the clock," said Vitaliy Kim, who heads the neighbouring Mykolaiv region.

Ukraine earlier said it had broken through Russia's first line of defence.

But Russia said Ukrainian troops had been defeated during a failed attack.

The defence ministry in Moscow also said there had been heavy casualties among the Ukrainian forces, but the claims by both Ukraine and Russia have not been independently verified.

Kherson became the first major Ukrainian city to fall into Russian hands in the opening days of the invasion in late February on 24 February.

Top Ukrainian military officials have been tight-lipped about giving too many details about its reported counter-offensive, urging the wider public to be patient.

On Tuesday, Ukraine's Operational Command South reported that "positional battles continue".

It said three key bridges across the Dnipro River had been hit again to make sure they were impassable. In recent weeks, Ukraine has also been using US-supplied HIMARS precision rocket systems to target makeshift Russian pontoon bridges, as well as command posts and ammunition depots.

This is widely seen as part of a targeted effort to cut off Russian troops on the right (western) bank of the river, making it virtually impossible to send troops and weapons resupplies.

However, officials in Kyiv have been cautioning against any expectations of a quick win, describing the offensive as a slow grinding down of the enemy.

Several military experts interviewed by the BBC seem to agree with this.

"The long-term trend is the gradual weakening of the Russian military capability and the gradual strengthening of the Ukrainian capability with Western help," said Sir Alex Younger, a former head of Britain's MI6 Secret Intelligence Service.

He said the Kherson counter-offensive was "all about the urge of Ukraine to demonstrate they can get on the front foot and in turn underpin the resolve of Ukraine and its backers into what is going to be a difficult winter". —BBC

UPPER DENKYIRA EAST MUNICIPAL ASSEMBLY INVITATION TO TENDER | PROCUREMENT OF GOODS NATIONAL COMPETITIVE TENDERING (NCT)

1. The Upper Denkyira East Municipal Assembly has been allocated funds from the District Assemblies Common Fund - Responsive Factor Grant (DAFC-RFG) and intends to apply the funds to cover eligible payments under the contract for the procurement of the under listed goods:

LOT NO.	IFT PACKAGE NO.	CONTRACT DESCRIPTION	QUANTITY (NO)	LOCATION	DELIVERY PERIOD	TENDER SECURITY
LOT 1	CR/UDE-MA/DACF-RFG/NCT/GDS/001/22	SUPPLY OF 600No. DUAL DESK FOR 15No. BASIC SCHOOLS IN THE MUNICIPALITY.	VARIOUS	DUNKWA-ON-OFFIN	3 WEEKS	2 % OF THE TOTAL TENDER PRICE

1. The Upper Denkyira East Municipal Assembly now invites sealed Tenders from eligible Suppliers for the Supply of Goods listed above. Tendering will be conducted through the National Competitive Tendering (NCT) procedures specified in the Public Procurement Act, Act 663, 2003 and the Public Procurement (Amendment) Act 2016 Act 914 and the Guidelines of the Public Procurement Authority of the Republic of Ghana.

2. Interested eligible tenderers may obtain further information from the Office of the Upper Denkyira East Municipal Co-ordinating Director, and inspect the Tender documents at the address given below from 09:00 hours to 17:00 hours GMT on working days.

3. Tender documents (and additional copies) may be purchased at the address stated below for a non-refundable fee of Three Hundred Ghana Cedis (GH¢300.00) only, for each set. The document will be obtained personally and with an application letter. Tenderers are advised to use the address stated below for obtaining information, inspection and purchase of Tender Document.

4. Tenders must be deposited into the box located at the address below at or before 10:00 hours GMT on 2nd September 2022. Tenders shall be valid for a period of 90 days after the deadline of Tender submission. All Tenders must be accompanied by

a Tender Security of 2 % of the total Tender price stated in the table above for each package. Late Tenders will be rejected. Tenders will be opened in the presence of the Tenderer's representative, who chooses to attend at the Conference Room of the Upper Denkyira East Municipal Assembly at 10.00 hours GMT on 16th September, 2022.

Address for information, inspection and purchase of Tender Document
Name: The Municipal Co-ordinating Director
Upper Denkyira East Municipal Assembly
Postal Address: P. O. Box DW 50,
City: Dunkwa-on-Offin
Region: Central
Country: Ghana
Telephone Number: 0332229145

Address for Tender submission and opening
Name: The Secretary,
Municipal Tender Committee
Upper Denkyira East Municipal Assembly
Postal Address: P. O. Box DW 50
City: Dunkwa-on-Offin
Region: Central
Country: Ghana
Location for Tender Submission is: Office of the Municipal Co-ordinating Director

UNIVERSITY OF ENERGY AND NATURAL RESOURCES (UENR), SUNYANI-GHANA



INVITATION FOR TENDERS NATIONAL COMPETITIVE TENDERING (NCT)

1. The University of Energy and Natural Resources, Sunyani intends to apply part of its budgetary allocation to fund eligible payments under the contracts for the supply of the underlisted items:

S/No	Description	Quantity	Contract Package No.	Cost of Tender Document
1	Procurement of 4 x 4 SUV Vehicle for the Regional Centre for Energy and Environmental Sustainability (RCEES), UENR	1 No.	BA/UENR/GD/010/22 (BA/UENR/RCEES/GD/010/22)	GHC 500.00
2	Procurement of Furniture for the Regional Centre for Energy and Environmental Sustainability (RCEES), UENR: Lot 2A: Office Furniture, Lot 2B: Auditorium Furniture, Lot 2C: Lecture Hall Furniture Lot 2D: Laboratory Furniture	Various	BA/UENR/GD/006/22 BA/UENR/GD/009/22 (BA/UENR/RCEES/GD/007/22)	GHC 500.00 for each Lot.

2. The University of Energy and Natural Resources, Sunyani now invites sealed Tenders from eligible suppliers for the Supply of the above listed items. Tendering will be conducted through the National Competitive Tendering (NCT) method procedures specified in the Public Procurement Act 2003 (Act 663) as amended, and the Guidelines of the Public Procurement Authority (PPA) of the Republic of Ghana.

3. Tenderers may obtain further information and inspect the tender document at the UENR Procurement Directorate Building from 9:00am to 4:00pm, each working day from Wednesday, 31st August, 2022.

4. A complete set of Tender Documents in English may be purchased by the interested Tenderers upon submission of a written application to the address below and upon payment of a non-refundable fee of **GHC 500.00 for Tender Document for each package at the Finance Directorate, UENR.**

NB: GHC 500.00 for the package Serial Number 1 (S/NO 1) and each Lot in Serial Number 2 (S/NO 2).

5. Tenders must be delivered to the address below at or before **11:00 a.m. on Tuesday, 20th September, 2022.** Tenders shall be valid for **120 days** after the deadline of submission of Tenders. All tenders must be accompanied by a Tender Security of **2% of the Tender price.**

Late Tenders will not be accepted and will be returned unopened to the Tenderer. Tenders will be opened immediately after the closing time of submission of tenders in the presence of the Tenderers' representatives, who choose to attend at the University's Council Chamber, University of Energy and Natural Resources, Sunyani at 11:00 a.m., on Tuesday, 20th September, 2022.

6. Address for purpose of Tender submission:

The Vice-Chancellor
ATTN: Ag. Director of Procurement
University of Energy and Natural Resources
P.O. Box 214
Sunyani, Ghana

7. Location for the submission of tenders:

The Procurement Directorate Building
Opposite UENR Basic School
University of Energy and Natural Resources
(UENR) Sunyani, Ghana
Telephone: 0352290367/0244535464
Email: procurementdirector@uenr.edu.gh

8. It is mandatory that Tenderers include in their tender the underlisted statutory requirements.

- Valid GRA Tax Clearance Certificate.
- Valid SSNIT Clearance Certificate.
- Valid VAT Registration Certificate.
- Valid Business Registration Certificate.
- Valid Certificate of Incorporation.
- Valid Certificate of Commencement.
- Valid Registration Certificate from PPA.

REGISTRAR



UNIVERSITY OF ENERGY AND NATURAL RESOURCES, SUNYANI OFFICE OF THE PROCUREMENT DIRECTORATE

P. O. Box 214, Sunyani

www.uenr.edu.gh

+233 (0) 352 290 367

procurementdirector@uenr.edu.gh

Our Ref: PD/VC/NCT/SF.3/003/2022

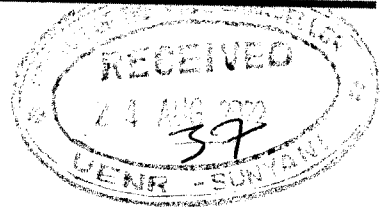

MEMO

TO : VICE-CHANCELLOR
FROM : AG. DIRECTOR OF PROCUREMENT
DATE : 24TH AUGUST, 2022
SUBJECT: REQUEST FOR APPROVAL

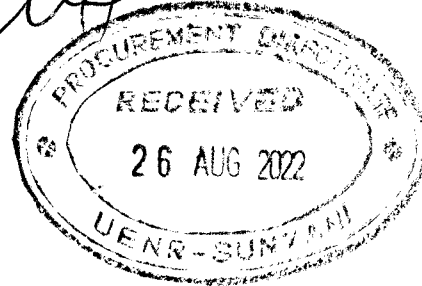

I write to request for your approval for the attached advertisement and its subsequent publication in the Newspapers.

Please find attached the advertisement for your review and approval.

Thank you.

② Attached Goods/ Services for

Ag. Dir, Procurement
Request approved
DAB 26/8/2022

Please liaise with URO to place the attached advert in Ghanaian Times (one insertion)





University of Energy and Natural Resources, Sunyani
Invitation for Tenders
National Competitive Tendering (NCT)

1. The University of Energy and Natural Resources, Sunyani intends to apply part of its budgetary allocation to fund eligible payments under the contracts for the supply of the underlisted items:

S/NO	Description	Quantity	Contract Package No.	Cost of Tender Document
1	Procurement of 4 x 4 SUV Vehicle for the Regional Centre for Energy and Environmental Sustainability (RCEES), UENR	1 No.	BA/UENR/RCEES/GD/010/22	GHC 500.00
2	Procurement of Furniture for the Regional Centre for Energy and Environmental Sustainability (RCEES), UENR: Lot 2A: Office Furniture, Lot 2B: Auditorium Furniture, Lot 2C: Lecture Hall Furniture Lot 2D: Laboratory Furniture	Various	BA/UENR/RCEES/GD/007/22	GHC 500.00 for each Lot.

2. The University of Energy and Natural Resources, Sunyani now invites sealed Tenders from eligible suppliers for the Supply of the above listed items:

Tendering will be conducted through the **National Competitive Tendering (NCT) method** procedures specified in the **Public Procurement Act 2003 (Act 663) as amended**, and the **Guidelines of the Public Procurement Authority (PPA)** of the Republic of Ghana.

3. Tenderers may obtain further information and inspect the tender document at the **UENR Procurement Directorate Building from 9:00am to 4:00pm**, each working day from **Tuesday, 30th August, 2022**.
4. A complete set of Tender Documents in English may be purchased by the interested Tenderers upon submission of a written application to the address below and upon payment of a non- refundable fee of **GHC 500.00 for Tender Document for each package at the Finance Directorate, UENR**.
- NB:** *GHC 500.00 for the package Serial Number 1 (S/NO 1) and each Lot in Serial Number 2 (S/NO 2).*

5. Tenders must be delivered to the address below at or before **11:00 a.m. on Tuesday, 20th September, 2022**. Tenders shall be valid for **120 days** after the deadline of submission of Tenders. All tenders must be accompanied by a Tender Security of **2% of the Tender price**. **Late Tenders will not be accepted and will be returned unopened to the Tenderer**. Tenders will be opened immediately after the closing time of submission of tenders in the presence of the Tenderers' representatives, who choose to attend at **the University's Council Chamber, University of Energy and Natural Resources, Sunyani** at **11:00 a.m., on Tuesday, 20th September, 2022**.

6. **Address for purpose of Tender submission:**

**The Vice-Chancellor
ATTN: Ag. Director of Procurement
University of Energy and Natural Resources
P.O. Box 214
Sunyani, Ghana**

7. **Location for the submission of tenders:**

**The Procurement Directorate Building
Opposite UENR Basic School
University of Energy and Natural Resources (UENR)
Sunyani, Ghana
Telephone: 0352290367/0244535464**

Email: procurementdirector@uenr.edu.gh

8. It is mandatory that Tenderers include in their tender the underlisted statutory requirements.
- Valid GRA Tax Clearance Certificate.
 - Valid SSNIT Clearance Certificate.
 - Valid VAT Registration Certificate.
 - Valid Business Registration Certificate.
 - Valid Certificate of Incorporation.
 - Valid Certificate of Commencement.
 - Valid Registration Certificate from PPA.

UNIVERSITY OF ENERGY AND NATURAL RESOURCES, SUNYANI

TENDER EVALUATION FOR THE NATIONAL COMPETITIVE TENDERING: PROCUREMENT OF FURNITURE FOR THE REGIONAL CENTRE FOR ENERGY AND ENVIRONMENTAL SUSTAINABILITY (RCEES), UENR:

LOT 2C: LECTURE HALL FURNITURE

S/NO 2C

**BA/UENR/GD/006/22, BA/UENR/GD/009/22
(BA/UENR/RCEES/GD/007/22)**

STAGE 1: PRELIMINARY REQUIREMENTS

No	Name of Tenderer(s)	Tender Signed	Business Reg. cert	VAT certificate	Valid Tax Clearance Cert	Valid SSNIT Clearance Cert	PPA Reg. Cert	Tender Security-Bond or Bank Guarantee (2% of Tender Price)	Responsive/ Non-Responsive
1	White Pleasure Company Limited	✓	✓	✓	14/10/22	19/10/22	23/09/2022	Bid Bond from Hollard Insurance GH¢23,421.89	Responsive
2	Mat-Bans Company Limited	✓	✓	✓	14/10/22	16/10/22	01/09/23	Bid Bond from Phoenix Insurance GH¢51,620.00	Responsive
3	Contra-Focus Limited	✓	✓	✓	22/09/22	25/09/22	05/01/23	Bid Bond from SIC Insurance GH¢73,000.00	Responsive
4	Yekna Investment Limited	✓	✓	✓	04/10/22	29/09/22	07/11/22	Bid Bond from Phoenix Insurance GH¢40,000.00	Responsive

Signed.....
(Chairman, Tender Evaluation Panel)

Date.....

Signed.....
(Secretary, Tender Evaluation Panel)

Date.....

UNIVERSITY OF ENERGY AND NATURAL RESOURCES, SUNYANI

TENDER EVALUATION FOR THE NATIONAL COMPETITIVE TENDERING: PROCUREMENT OF FURNITURE FOR THE REGIONAL CENTRE FOR ENERGY AND ENVIRONMENTAL SUSTAINABILITY (RCEES), UENR:

LOT 2C: LECTURE HALL FURNITURE

S/NO 2C

BA/UENR/GD/006/22, BA/UENR/GD/009/22

(BA/UENR/RCEES/GD/007/22)

STAGE 2: COMMERCIAL RESPONSIVENESS

	White Pleasure Company Limited	Mat-Bans Company Limited	Contra-Focus Limited	Yekna Investment Limited
REQUIREMENTS				
Payment Terms (Payments shall be done in installments but not exceeding nine months after delivery)	As Per Tender Document	As Per Tender Document	Payments shall be done in installments but not exceeding nine months after delivery	Not Provided
Delivery Period: (at most 8 Weeks)	As Per Tender Document	As Per Tender Document	8 Weeks After Award of Contract	Within 8 Weeks
Tender Validity Period: (at least 120 days)	As Per Tender Document	As Per Tender Document	180 Days	120 Days
Power of Attorney	Provided	Provided	Provided	Provided
After Sales Service: Tenderers should be able to Provide After Sale Services Facilities for one (1) Year after delivery of the Furniture they intend to supply (Statement of After Sale Service should be provided as evidence).	Provided	Provided	Provided	Provided
Warranty Period (at least one year from date of Delivery)	As Per Tender Document (2021 and 2020)	As Per Tender Document (2021 and 2020)	24 Month After Deliver	Provided
Audited financial Accounts for 2020 and 2021	As Per Tender Document (2021 and 2020)	Provided (2021 and 2020)	Provided (2021 and 2020)	Not Provided
List of at least three (3) References for similar supply.	Provided	Provided	Provided	Provided
Responsive/ Non-Responsive	<i>Responsive</i>	<i>Responsive</i>	<i>not responsive</i>	<i>Not responsive</i>

Signed.....
 (Chairman, Tender Evaluation Panel)
 Date.....

Signed.....
 (Secretary, Tender Evaluation Panel)
 Date.....

UNIVERSITY OF ENERGY AND NATURAL RESOURCES, SUNYANI

TENDER EVALUATION FOR THE NATIONAL COMPETITIVE TENDERING: PROCUREMENT OF FURNITURE FOR THE REGIONAL CENTRE FOR ENERGY AND ENVIRONMENTAL SUSTAINABILITY (RCEES), UENR:

LOT 2C: LECTURE HALL FURNITURE



S/NO 2C

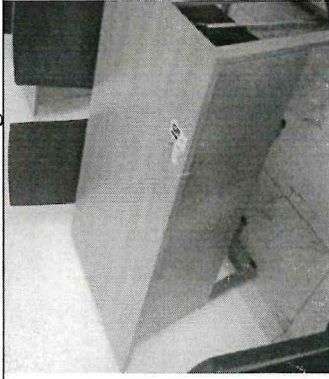

BA/UENR/GD/006/22, BA/UENR/GD/009/22

(BA/UENR/RCEES/GD/007/22)

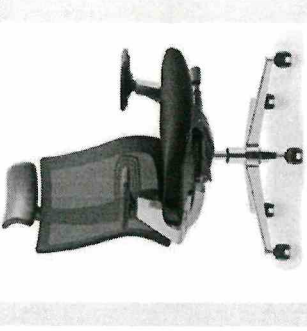
STAGE 3: TECHNICAL EVALUATION

No.	MINIMUM REQUIRED SPECIFICATION	Qty	OFFERED SPECIFICATION			
			White Pleasure Company Limited	Mat-Bans Company Limited	Contra-Focus Limited	Yekna Investment Limited
	LECTURE HALL A GROUND FLOOR					
1	<p>2 In 1 Tables with Stationary Chairs: Standard Straight Desk, Legs made of aluminum, Smooth surface, Polished Wood, Durable and comfortable for lecture hall, Dimension 1.6M in length</p> 	18 No.		Complied		
			Not Complied	Complied		
2	<p>Single Table With Metal Legs: Standard Straight Desk, Legs made of aluminum, Smooth surface, Polished Wood, Durable and comfortable for lecture hall, Dimension 1.0M in length</p>	6 No.		Complied		
3	<p>Lecturer Table: Standard Straight Desk, Legs made of aluminum, Smooth surface, Polished Wood, Durable and comfortable for lecture hall, Dimension 1.4M in length, Movable Table</p>	4 No.		Complied		

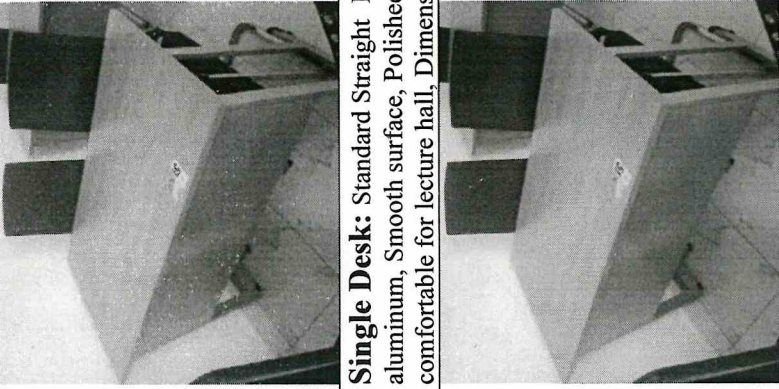
		White Pleasure Company Limited	Mat-Bans Company Limited	Contra-Focus Limited	Yekna Investment Limited
4	<p>Lecturer Swivel Chair: Black Vinyl Upholstery Seat with Passive Lumbar support Pneumatic Seat Height Adjustment, Black Nylon Loop Arms Heavy-Duty Nylon Base, Dual Wheel Carpet Casters, Dimensions: Overall: 41"-45"(H), Seat Size: 20" (W)X 19.5" (D), Seat height: 17"-21"H, Back Size: 20" (W) X 26" (H), Finish: Black /Brown, Black Nylon Loop Arms Heavy-Duty Nylon Base, Adjustable Handle with Mesh Back</p> 	4 No.	Complied		
5	<p>Swivel Chairs: Leather Swivel chair, PU upholstery front back and seat, PVC backing, Black Nylon Loop Arms Heavy-Duty Nylon Base, Dual Wheel Carpet Casters, Durable and Comfortable, Plastic Handle, Adjustable Height, Colour: Black</p> 	42 No.	Complied		
1 ST FLOOR LECTURE HALL B					
6	<p>2 In 1 Desk: Standard Straight Desk, Legs made of aluminum, Smooth surface, Polished Wood, Durable and comfortable for lecture hall, Dimension 1.6M in length</p>	17 No.	Complied		

			White Pleasure Company Limited	Mat-Bans Company Limited	Contra-Focus Limited	Yekna Investment Limited
				Completed		
7	Single Desk: Standard Straight Desk, Legs made of aluminum, Smooth surface, Polished Wood, Durable and comfortable for lecture hall, Dimension 1.0M in length	3 No.	Completed	Completed		
8	Swivel Chair: Leather Swivel chair, PU upholstery front back and seat, PVC backing, Black Nylon Loop Arms Heavy-Duty Nylon Base, Dual Wheel Carpet Casters, Durable and Comfortable, Plastic Handle, Adjustable Height, Colour: Black	37 No.	Not	Completed		
				Completed		

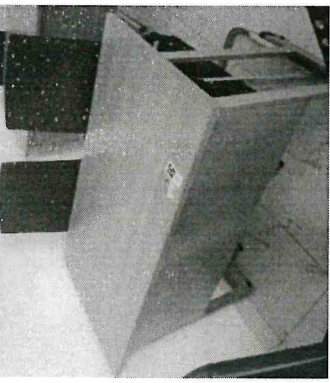
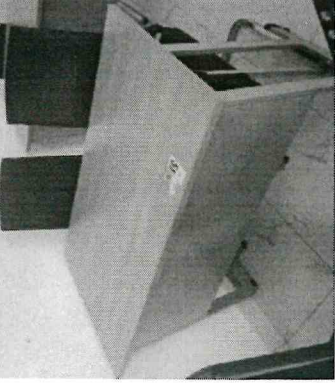
			White Pleasure Company Limited	Mat-Bans Company Limited	Contra-Focus Limited	Yekna Investment Limited
9	1 ST FLOOR LECTURE HALL C 2 In 1 Desk: Standard Straight Desk, Legs made of aluminum, Smooth surface, Polished Wood, Durable and comfortable for lecture hall, Dimension 1.6M in length 	17 No.	Completed	Completed		
10	Single Desk: Standard Straight Desk, Legs made of aluminum, Smooth surface, Polished Wood, Durable and comfortable for lecture hall, Dimension 1.0M in length 	3 No.	Completed	Completed		
11	Swivel Chair: Leather Swivel chair, PU upholstery front back and seat, PVC backing, Black Nylon Loop Arms Heavy-Duty Nylon Base, Dual Wheel Carpet Casters, Durable and Comfortable, Plastic Handle, Adjustable Height, Colour: Black	37 No.	Not Completed	Completed		

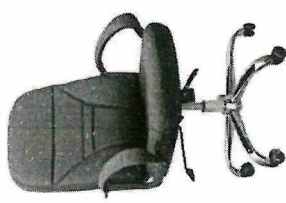
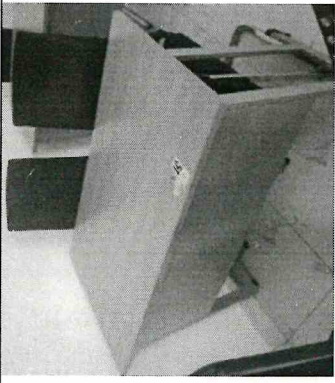
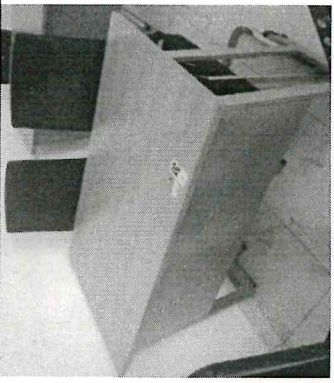
			White Pleasure Company Limited	Mat-Bans Company Limited	Contra-Focus Limited	Yekna Investment Limited
				Completed		
1ST FLOOR LECTURE HALL – D						
12		18 No.	Completed	Completed		
			Completed			
13		6 No.	NOT Completed	Completed		
				Completed		

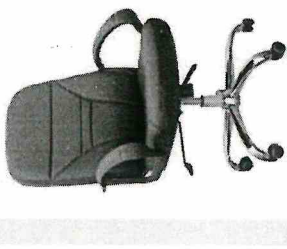
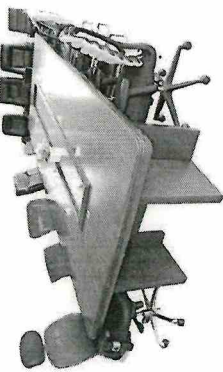

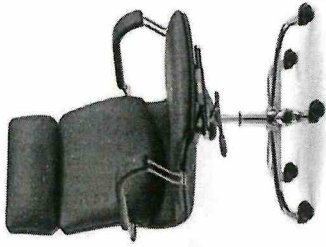
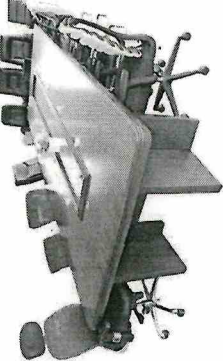
			White Pleasure Company Limited	Mat-Bans Company Limited	Contra-Focus Limited	Yekna Investment Limited
14	<p>Swivel Chair: Leather Swivel chair, PU upholstery front back and seat, PVC backing, Black Nylon Loop Arms Heavy-Duty Nylon Base, Dual Wheel Carpet Casters, Durable and Comfortable, Plastic Handle, Adjustable Height, Colour: Black</p> 	42 No.		Complied		
SEMINAR ROOM A- GROUND FLOOR						
15	<p>14 Seater Conference Table with Chairs: Executive design, 6 Meters dimensions, Rectangular in shape, Coffee in colour, Durable Wooden Table, Special Feature Suitable for Office, Computer, Laptop , General use</p> 	1 No.	Complied	Complied		
16	<p>Swivel Chairs: Leather Swivel chair, PU upholstery front back and seat, PVC backing, Chromed sleight frame, Head Rest Support, Adjustable Height, Durable and Comfortable for long hour of meeting, Padded leather Handle, Seat height: 17"-21"H, Back Size: 20" (W) X 26" (H), Colour: Black</p>	14 No.	Complied	Complied		

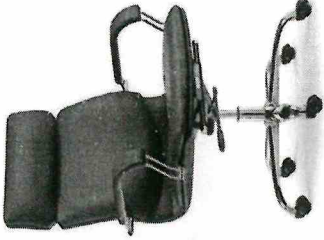
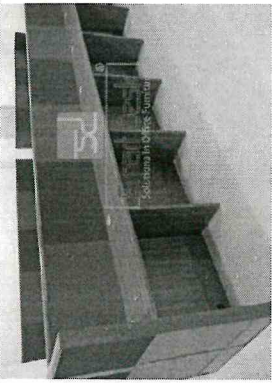

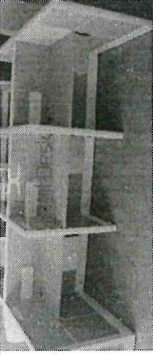
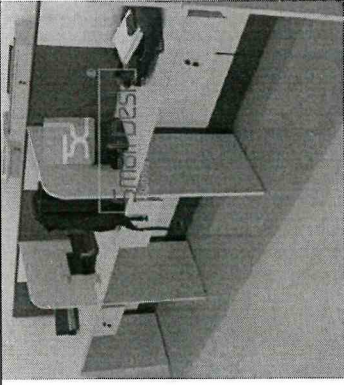
		White Pleasure Company Limited	Mat-Bans Company Limited	Contra-Focus Limited	Yekna Investment Limited
			Completed		
SEMINAR ROOM B- GROUND FLOOR					
17	14 Seater Conference Table With Chairs: Executive design, 6 Meters dimensions, Rectangular is shape, Coffee in colour, Durable Wooden Table, Special Feature Suitable for Office, Computer, Laptop , General use	Completed	Completed		
		Not Completed	Completed		
18	Swivel Chairs: Leather Swivel chair, PU upholstery front back and seat, PVC backing, Chromed sleight frame, Head Rest Support, Adjustable Height, Durable and Comfortable for long hour of meeting, Padded leather Handle, Seat height: 17"-21"H, Back Size: 20" (W) X 26" (H), Colour: Black	Not Completed	Completed		

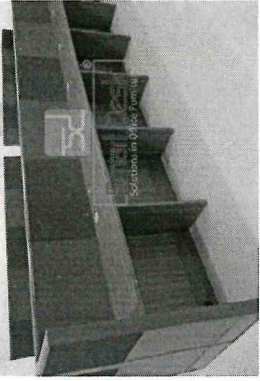
		White Pleasure Company Limited	Mat-Bans Company Limited	Contra-Focus Limited	Yekna Investment Limited
			Complied		
PHD STUDY ROOM					
19	<p>4 Seater Workstation: 4 Seater Straight workstation with Cabinets, 1.0M dimension per student, Wooden Cabinet fit to the wall for storage, Durable laminate construction is stain and scratch resistant Easy assembly (assembles in under 30 minutes), Locking pedestals can be configured left or right, Box-frame legs are constructed of 14-gauge steel, Polished Surface, Surface is 0.6M, Thickness Partition: 4.5CM, Has Electronic holes for laptop and desktop computers, printers etc</p> 	5 No.	Complied		
20	<p>5 Seater Workstation (1.0M): 4 Seater Straight workstation with Cabinets, 1.0M dimension per student, Wooden Cabinet fit to the wall for storage, Durable laminate construction is stain and scratch resistant, Easy assembly (assembles in under 30 minutes), Locking pedestals can be configured left or right, Box-frame legs are constructed of 14-gauge steel, Polished Surface, Surface is 0.6M, Thickness, Partition: 4.5CM, Has Electronic holes for laptop and desktop computers, printers etc</p>	5 No.	Complied		

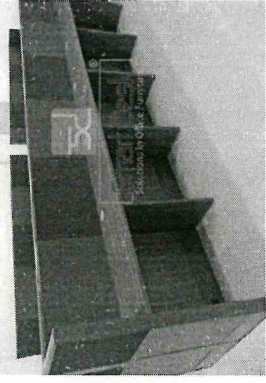

		White Pleasure Company Limited	Mat-Bans Company Limited	Contra-Focus Limited	Yekna Investment Limited
			Completed		
21	<p>7 Seater Workstation (1.0M): 7 Seater Straight workstations with Cabinets, 1.0M dimension per student, Wooden Cabinets fit to the wall for storage, Durable laminate construction is stain and scratch resistant, Easy assembly (assembles in under 30 minutes), Locking pedestals can be configured left or right, Box-frame legs are constructed of 14-gauge steel, Polished Surface, Surface is 0.6M, Thickness Partition: 4.5CM, Has Electronic holes for laptop and desktop computers, printers etc</p> 		Completed		
MASTERS STUDY HALL					
22	<p>4 Seater Workstation: 4 Seater Straight workstation with Cabinets, 1.0M dimension per student, Wooden Cabinet fit to the wall for storage, Durable laminate construction is stain and scratch resistant Easy assembly (assembles in under 30 minutes), Locking pedestals can be configured left or right, Box-frame legs are constructed of 14-gauge steel, Polished Surface, Surface is 0.6M, Thickness Partition: 4.5CM, Has Electronic holes for laptop and desktop computers, printers etc</p>	Completed	Completed		

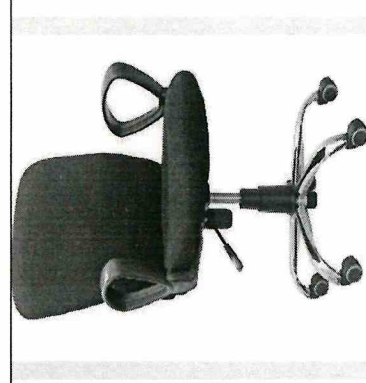

		White Pleasure Company Limited	Mat-Bans Company Limited	Contra-Focus Limited	Yekna Investment Limited
			<i>Completed</i>		
23	<p>5 Seater Workstation (1.0M): 4 Seater Straight workstation with Cabinets, 1.0M dimension per student, Wooden Cabinet fit to the wall for storage, Durable laminate construction is stain and scratch resistant, Easy assembly (assembles in under 30 minutes), Locking pedestals can be configured left or right, Box-frame legs are constructed of 14-gauge steel, Polished Surface, Surface is 0.6M, Thickness Partition: 4.5CM, Has Electronic holes for laptop and desktop computers, printers etc</p>	<i>Completed</i>	<i>Completed</i>		
			<i>Completed</i>		
24	<p>7 Seater Workstation (1.0M): 7 Seater Straight workstations with Cabinets, 1.0M dimension per student, Wooden Cabinets fit to the wall for storage, Durable laminate construction is stain and scratch resistant, Easy assembly (assembles in under 30 minutes), Locking pedestals can be configured left or right, Box-frame legs are constructed of 14-gauge steel, Polished Surface, Surface is 0.6M, Thickness Partition: 4.5CM, Has Electronic holes for laptop and desktop computers, printers etc</p>	<i>Completed</i>	<i>Completed</i>		

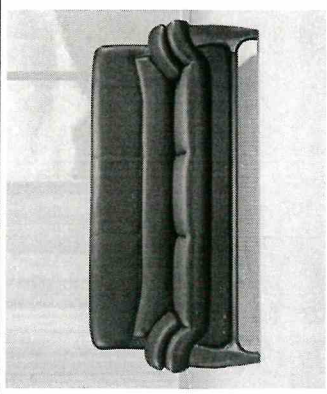
		White Pleasure Company Limited	Mat-Bans Company Limited	Contra-Focus Limited	Yekna Investment Limited
			<i>Completed</i>		
PHD and Masters Study Hall					
25	<p>Swivel Chair: Black Vinyl Upholstery Seat with Passive Lumbar support Pneumatic Seat Height Adjustment, Black Nylon Loop Arms Heavy-Duty Nylon Base, Dual Wheel Carpet Casters, Dimensions: Overall: 41"-45"(H), Seat Size: 20" (W)X 19.5"(D), Seat height: 17"-21"H, Back Size: 20" (W) X 26" (H), Finish: Black /Brown, Black Nylon Loop Arms Heavy-Duty, Nylon Base</p> 	<i>80</i>	<i>Completed</i>		
LIBRARY HALL					
26	<p>Metal With Wood Curve Workstation: Executive design, 14 Meters dimensions, Curve is shape, Coffee in colour, Durable Wooden Table, Partition of 1.0M per student</p>		<i>Completed</i>		

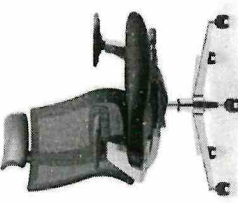
			White Pleasure Company Limited	Mat-Bans Company Limited	Contra-Focus Limited	Yekna Investment Limited
				Complied		
27	20 Seating Capacity Library Tables: Executive design, 14 Meters dimensions, Rectangular in shape, Coffee in colour, Durable Wooden Table, Partition of 1.0M per student	11 No.	Complied	Complied		
			Complied	Complied		
28	Library Swivel Chair: Office Swivel Chair, Black Vinyl Upholstery seat with Passive Lumber support Pneumatic Seat Height Adjustment, Black Nylon Loop Arms Heavy-Duty Nylon Base, Dual Wheel Carpet Casters, Arm rest	20 No.	Not	Complied		
				Complied		

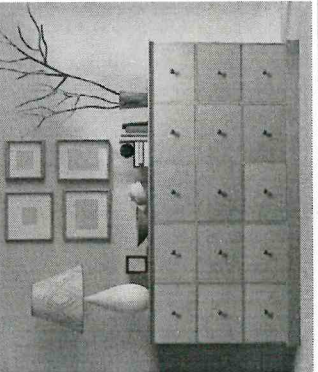
			White Pleasure Company Limited	Mat-Bans Company Limited	Contra-Focus Limited	Yekna Investment Limited
29	<p>Metal Library Bookshelves: High quality cold-rolled plate, Hardness to meet the load bearing requirement, Flexible combination, Scientific division, User –Friendly design, Anti-corrosion moisture, Easy to install and remove, simple and convenient</p> 	5 No.		Complied		
30	<p>3 In 1 Sofa</p> 	1 No.	Complied	Complied		
31	<p>Executive Swivel Chair: Executive Mesh Swivel Chair, Black Vinyl Upholstery seat with Passive Lumber support Pneumatic Seat Height Adjustment, Black Nylon Loop Arms Heavy-Duty Nylon Base, Dual Wheel Carpet Casters, Arm rest and head rest, Adjustable handle, Dimension: 22.5" x 22" 33H</p>	1 No.		Complied		

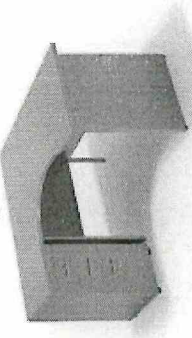
			White Pleasure Company Limited	Mat-Bans Company Limited	Contra-Focus Limited	Yekna Investment Limited
				Completed		
32	Visitor Chair: Fully upholstered in high grade black Mesh, Chrome base and chrome arms (metal arms), Seat Height: (min-max) 450mm-530mm, Back width X Height: Medium Back 520 x 580mm, Back Width x Height High back: 520mm x 700mm, Seat Width x Depth: 520mm x 520mm, Seat Width x Depth: including arms: 630mm	4 No.		Completed		
			Completed			
33	24 Pigeon Holes Cabinet: Metal shelves into cube size, Partition into 24 holes, Key lock for every hole, Each hole is 17 x 17 inches, Durable and Executive in nature, Suitable for a Library	1 Set	Completed	Completed		
			Not Completed	Completed		
34	Executive 1.6M Desk: Executive L-Shaped Office Desk With Chest of Drawers, L-Shaped and drawers are movable, Padded writing space, Material Make: Made of Hard Chip, First Grade, Polished wood with smooth surface, Durable, Colour: Cherry or Coffee, Size: 1.6M	1 No.		Completed		

		White Pleasure Company Limited	Mat-Bans Company Limited	Contra-Focus Limited	Yekna Investment Limited
			Complied		
35	Swivel Chair: Office Mesh Swivel Chair, Black Vinyl Upholstery seat with Passive Lumber support Pneumatic Seat Height Adjustment, Black Nylon Loop Arms Heavy-Duty Nylon Base, Dual Wheel Carpet Casters, Arm and Head rest, Dimension: 22.5" x 22" 33H	Complied	Complied		
		Not	Complied		
	Responsive/ Non-Responsive	NOT RESPONSIVE	RESPON SUC		

Signed.....*[Signature]*
 (Chairman, Tender Evaluation Panel)

Date.....05/10/2022

Signed.....*[Signature]*
 (Secretary, Tender Evaluation Panel)

Date.....05/10/2022

UNIVERSITY OF ENERGY AND NATURAL RESOURCES, SUNYANI

TENDER EVALUATION FOR THE NATIONAL COMPETITIVE TENDERING: PROCUREMENT OF FURNITURE FOR THE REGIONAL CENTRE FOR ENERGY AND ENVIRONMENTAL SUSTAINABILITY (RCEES), UENR: LOT 2C: LECTURE HALL FURNITURE

S/NO 2C

BA/UENR/GD/006/22, BA/UENR/GD/009/22
(BA/UENR/RCEES/GD/007/22)

STAGE 4: FINANCIAL EVALUATION

Name of Tenderers	Price Readout (GH¢)	Corrected Tender Price (GH¢)	Converted to Common Currency (GH¢)	Ranking	Recommended Tenderer	Justifications
White Pleasure Company Limited	1,054,706.63	1,054,706.63				
Mat-Bans Company Limited	818,800.00	818,800.00		1st	MAT-BANS COMPANY LIMITED	LOWER EVALUATION
Contra-Focus Limited	880,238.00	880,238.00				
Yekna Investment Limited	1,707,576.00	1,707,576.00				

Signed.....
(Chairman, Tender Evaluation Panel)

Signed.....
(Secretary, Tender Evaluation Panel)

Date.....

Date.....

UNIVERSITY OF ENERGY AND NATURAL RESOURCES, SUNYANI
TENDER EVALUATION FOR THE NATIONAL COMPETITIVE TENDERING: PROCUREMENT OF FURNITURE
FOR THE REGIONAL CENTRE FOR ENERGY AND ENVIRONMENTAL SUSTAINABILITY (RCEES), UENR:

LOT 2C: LECTURE HALL FURNITURE

S/NO 2C

BA/UENR/GD/006/22, BA/UENR/GD/009/22
 (BA/UENR/RCEES/GD/007/22)

STAGE 5: AFTER SALES SERVICE REQUIREMENT

Name of Tenderer(s)	Provision of After Sales Service Statement
MAT - BANIS COMPANY LIMITED	provided

Signed.....
 (Chairman, Tender Evaluation Panel)

Signed.....
 (Secretary, Tender Evaluation Panel)

Date.....

Date.....

TENDER EVALUATION COMMITTEE MEMBERS

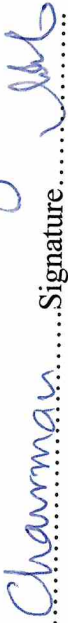
1. Name..... Prof. Simon Abugre
Designation..... Chairman
Signature..... 

3. Name..... John-baptist Sedlich
Designation..... member
Signature..... 

5. Name..... Kofi Basomah
Designation..... Secretary
Signature..... 

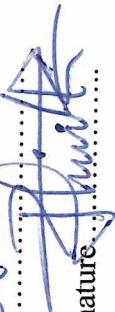
2. Name..... Paul Nana Nsofora
Designation..... member
Signature..... 

4. Name..... Kwadky Obeng Mireku
Designation..... member
Signature..... 

6. Name.....
Designation.....
Signature.....

7. Name.....
Designation.....
Signature.....

8. Name.....
Designation.....
Signature.....

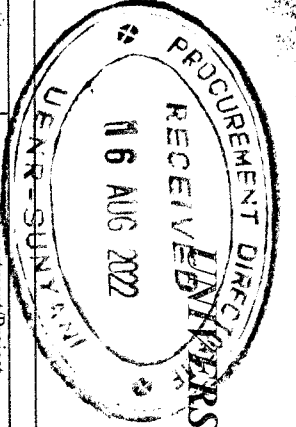

UNIVERSITY OF ENERGY AND NATURAL RESOURCES, SUNYANI
PROCUREMENT REQUISITION
GOODS

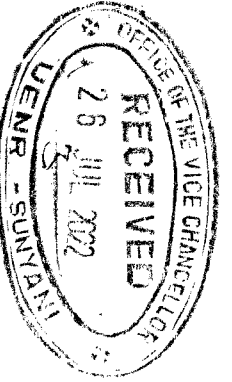
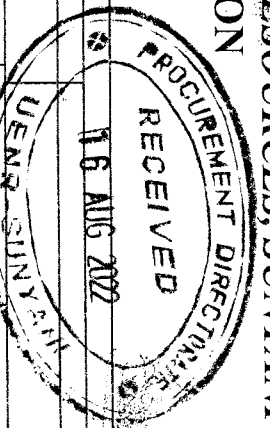

Procurement Entity: RENJ Department/Project: RCEES Source of Funds: PROJECT FUND Procurement Number: _____ Sequence Number: _____

Subject of Procurement: PROCUREMENT OF OFFICE FURNITURE Location/Site: _____

Item No.	Description	Quantity	Unit of Measure	Estimated Unit Cost	Estimated Total Cost
1.	Office Furniture <i>Refer to Attached</i>				750,000.00

Account Code:

Class: _____ Item: _____ Sub-Sub Item: _____

Definitive Total Cost:

750,000.00

Signatures required to certify that (1) the goods described are required, (2) included in the procurement plan, (3) funds are available or budgeted for the requirement, and (4) approval is granted the Procurement Director to proceed with the procurement process.

Signature:

[Signature]

Name:

Prof. Eric Ojosa Adomi

Position:

Director

Date:

10/08/2022

Signature: _____

[Signature]

Prof. Thomas M. ...
Vice-Chancellor

Signature: _____

[Signature]

Elvis Isaac-Holden
Vice-Chancellor

12/08/2022